

HSS KESİCİ TAKIMLAR ve KATER GRUBU

- Matkap Uçları (Uzun - Kısa)
- Matkap Uçları
- Mors Konik Saplı Matkap Uçları
- Punta Matkabi
- Düz Kanallı Makina Klavuzu
- Helis Kanallı Makina Klavuzu
- İnce Diş Makina Klavuzu
- UNC - Düz Makina Klavuzu
- UNF - Düz Makina Klavuzu
- Withworth Düz Makina Klavuzu
- Somun Klavuzu
- Trapez Torna Kalemı
- Manyetik Matkap Ucu
- Boru Vidalı Düz Makina Klavuzu
- Atlamalı Makina Klavuzu
- Ovalama Makina Klavuzu
- Havşa Frezesi 90°
- Pafta
- Pafta İnce Diş
- El ve Makina Raybaları
- T Yarık Freze
- Pim Raybası
- Ayarlı Rayba
- Pantoraf Kalemı
- Torna Kalemı
- Klavuz Kolu
- Pafta Kolu
- Delikli Havşa Frezesi
- Sabit Pilotlu Havşa Freze
- Köşe Yuvarlama Frezesi
- Ters Klavuz Seti
- Silindir Saplı Makina Raybası
- Mors Konik Saplı Makina Raybası
- Kısa - Uzun Parmak Freze
- Kaba Talaş Parmak Freze
- Otm. Klavuz Çekme Aparatı
- Ayarlı Delik Baraları
- Kollu Hassas Bara Takımları
- Tarama Başlıkları
- Saplı Tarama Başlıkları
- Vidalı Tarama Başlıkları
- Torna Katerleri (Sağ - Sol)
- Delik Katerleri
- Udrill Matkap
- Kanal Açma - Kesme Katerleri
- Kater Yedek Parçaları
- Daire Testereler

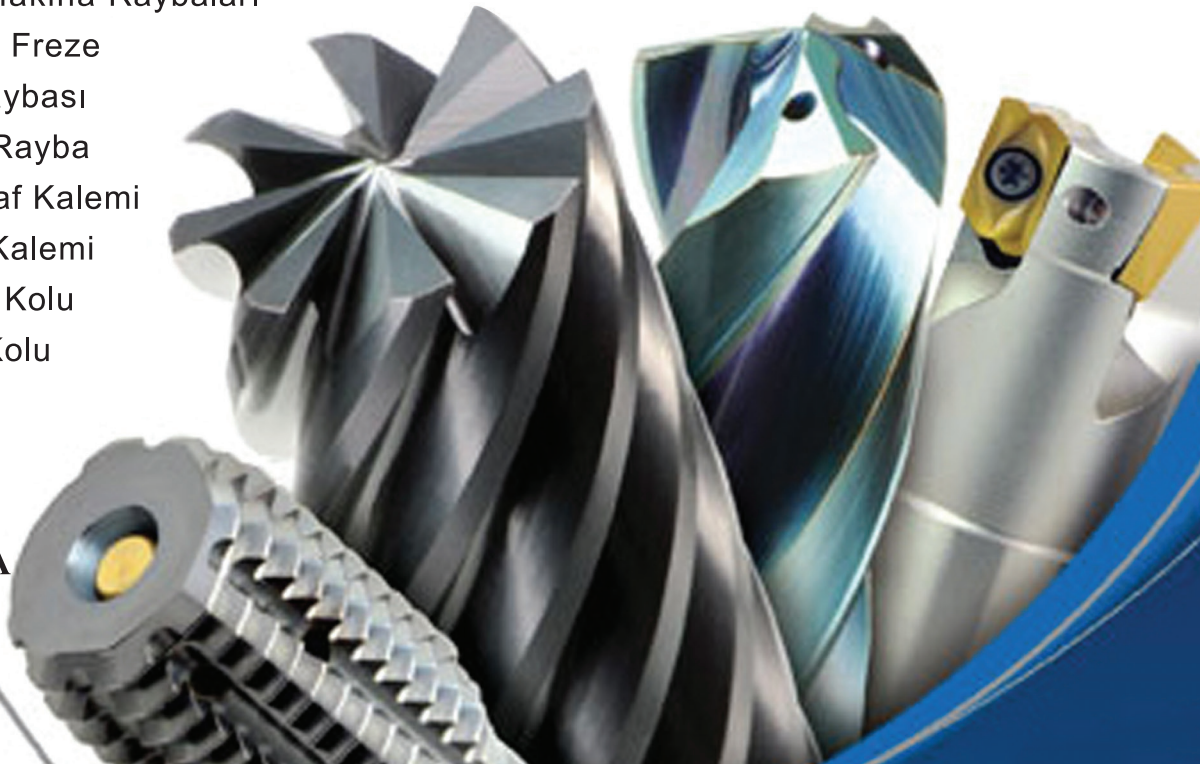

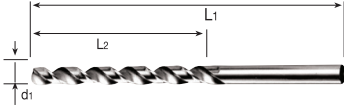

DIN 338 HSS MATKAP

d1 (mm)	L1	L2
0.4	20	5
0.5	22	6
0.6	24	7
0.7	28	9
0.8	30	10
0.9	32	11
1.0	34	12
1.1	36	14
1.2 - 1.3	38	16
1.4 - 1.5	40	18
1.6 - 1.7	43	20
1.8 - 1.9	46	22
2.0 - 2.1	49	24
2.2 - 2.3	53	27
2.4 - 2.6	57	30
2.7 - 3.0	61	33
3.1 - 3.3	65	36
3.4 - 3.7	70	39
3.8 - 4.2	75	43
4.3 - 4.7	80	47
4.8 - 5.3	86	52
5.4 - 6.0	93	57
6.1 - 6.7	101	63
6.8 - 7.5	109	69
7.6 - 8.5	117	75
8.6 - 9.5	125	81
9.6 - 10.6	133	87
10.7 - 11.8	142	94
11.9 - 13.2	151	101
13.3 - 14.0	160	108
14.1 - 15.0	169	114
15.1 - 16.0	178	120
16.5 - 17.0	184	125
17.5 - 18.0	191	130
18.5 - 19.0	198	135
19.5 - 20.0	205	140
20.5 - 21.0	213	145
22.5 - 23.0	229	155
23.5	229	155
24.0	236	160
24.5 - 25.0	236	160

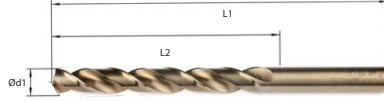

DIN 338 HSS-E ALTIN SERİ MATKAP

d1 (mm)	L1	L2
1.0	34	12
1.1	36	14
1.2 - 1.3	38	16
1.4 - 1.5	40	18
1.6 - 1.7	43	20
1.8 - 1.9	46	22
2.0 - 2.1	49	24
2.2 - 2.3	53	27
2.4 - 2.6	57	30
2.7 - 3.0	61	33
3.1 - 3.3	65	36
3.4 - 3.7	70	39
3.8 - 4.2	75	43
4.3 - 4.7	80	47
4.8 - 5.3	86	52
5.4 - 6.0	93	57
6.1 - 6.7	101	63
6.8 - 7.5	109	69
7.6 - 8.5	117	75
8.6 - 9.5	125	81
9.6 - 10.6	133	87
10.7 - 11.8	142	94
11.9 - 13.2	151	101
13.3 - 14.0	160	108
14.1 - 15.0	169	114
15.1 - 16.0	178	120
16.5 - 17.0	184	125
17.5 - 18.0	191	130
18.5 - 19.0	198	135
19.5 - 20.0	205	140
20.5 - 21.0	213	145
21.5 - 22.0	221	150
22.5 - 23.0	229	155
23.5	229	155
24.0	236	160
24.5 - 25.0	236	160

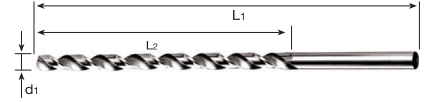

DIN 340 HSS UZUN MATKAP

d1 (mm)	L1	L2
1.0	56	33
1.1 - 1.4	65	41
1.5	70	45
1.6 - 1.9	80	53
2.0	85	56
2.1 - 2.4	95	62
2.5	95	62
2.6 - 2.9	100	66
3.0	100	66
3.1 - 3.4	112	73
3.5	112	73
3.6 - 3.9	119	78
4.0	119	78
4.1 - 4.4	119	78
4.5	126	82
4.6 - 4.9	132	87
5.0	132	87
5.1 - 5.4	139	91
5.5	139	91
5.6 - 5.9	139	91
6.0	139	91
6.1 - 6.4	148	97
6.5	148	97
6.6 - 6.9	156	102
7.0	156	102
7.1 - 7.4	156	102
7.5	156	102
7.6 - 7.9	165	109
8.0	165	109
8.1 - 8.4	165	109
8.5	165	109
8.6 - 8.9	175	115
9.0	175	115
9.1 - 9.4	175	115
9.5	175	115
9.6 - 9.9	184	121
10.0	184	121
10.1 - 10.4	184	121
10.5	184	121
11.0	195	128
11.5	195	128
12.0	205	134
12.5	205	134
13.0	205	134
13.5	214	140
14.0	214	140
14.5	220	144
15.0	220	144
15.5	227	149
16.0	227	149
16.5 - 17.0	235	154
17.5 - 18.0	241	158
18.5 - 19.0	247	162
19.5 - 20.0	254	166
22.0	268	176
23.0	275	180
24.0	282	185
25.0	282	185

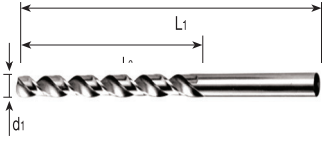

DIN 1869/1 HSS EKSTRA UZUN MATKAP

d1 (mm)	L1	L2
2.0	125	85
2.5	140	95
3.0	150	100
3.5	165	115
4.0	175	120
4.5	185	125
5.0	195	135
5.5	205	140
6.0	205	140
6.5	215	150
7.0	225	155
7.5	225	155
8.0	240	165
8.5	240	165
9.0	250	175
9.5	250	175
10.0	265	185
10.5	265	185
11.0	280	195
11.5	280	195
12.0	295	205
12.5	295	205
13.0	295	205

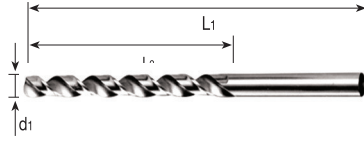

DIN 1869/2 HSS EKSTRA UZUN MATKAP

d1 (mm)	L1	L2
3.0	190	130
3.5	210	145
4.0	220	150
4.5	235	160
5.0	245	170
5.5	260	180
6.0	260	180
6.5	275	190
7.0	290	200
7.5	290	200
8.0	305	210
8.5	305	210
9.0	320	220
9.5	320	220
10.0	340	235
10.5	340	235
11.0	365	250
11.5	365	250
12.0	375	260
12.5	375	260
13.0	375	260

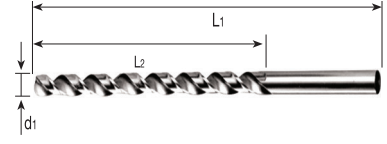

DIN 1869/3 HSS EKSTRA UZUN MATKAP

d1 (mm)	L1	L2
3.5	265	180
4.0	280	190
4.5	295	200
5.0	315	210
5.5	330	225
6.0	330	225
6.5	350	235
7.0	370	250
7.5	370	250
8.0	390	265
8.5	390	265
9.0	410	280
9.5	410	280
10.0	430	295
10.5	430	295
11.0	455	310
11.5	455	310
12.0	480	330
12.5	480	330
13.0	480	330

**DIN 345
HSS MORS KONİK SAPLI
MATKAP UCU**

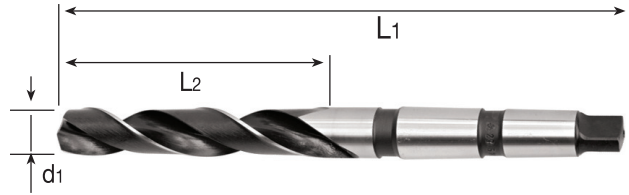

d1 (mm)	L1	L2
8.0	156	75
8.5	156	75
9.0	162	81
9.5	162	81
10.0	168	87
10.5	168	87
11.0	175	94
11.5	175	94
12.0	182	101
12.5	182	101
13.0	182	101
13.5	189	108
14.0	189	108
14.5	212	114
15.0	212	114
15.5	218	120
16.0	218	120
16.5	223	125
17.0	223	125
17.5	228	130
18.0	228	130
18.5	233	135
19.0	233	135
19.5	238	140
20.0	238	140

d1 (mm)	L1	L2
20.5	243	145
21.0	243	145
21.5	248	150
22.0	248	150
22.5	253	155
23.0	253	155
23.5	276	155
24.0	281	160
24.5	281	160
25.0	281	160
25.5	286	165
26.0	286	165
26.5	286	165
27.0	291	170
27.5	291	170
28.0	291	170
28.5	296	175
29.0	296	175
29.5	296	175
30.0	296	175
30.5	301	180
31.0	301	180
31.5	301	180
32.0	334	185
32.5	334	185

d1 (mm)	L1	L2
33.0	334	185
33.5	334	185
34.0	339	190
34.5	339	190
35.0	339	190
35.5	339	190
36.0	344	195
36.5	344	195
37.0	344	195
37.5	344	195
38.0	349	200
38.5	349	200
39.0	349	200
39.5	349	200
40.0	349	205
41.0	354	205
42.0	354	205
43.0	359	210
44.0	359	210
45.0	359	210
46.0	364	215
47.0	364	215
48.0	369	220
49.0	369	220
50.0	369	220

**DIN 333 A
HSS PUNTA MATKABI**

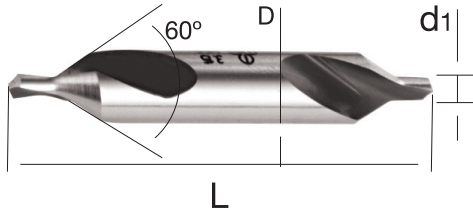

Normal Tip

d1	D	L
1.0	3.15	31.5
1.25	3.15	31.5
1.6	4.0	35.5
2.0	5.0	40.0
2.5	6.3	45.0
3.15	8.0	50.0
4.0	10.0	56.0
5.0	12.5	63.0

Uzun Tip (İthal)

d1	D	L
2.0	5.0	76
2.5	6.3	102
3.15	8.0	102
4.0	10.0	127
5.0	12.5	127
6.3	16.0	127

**DIN 352
HSS 3'LÜ TAKIM KLAUZ**

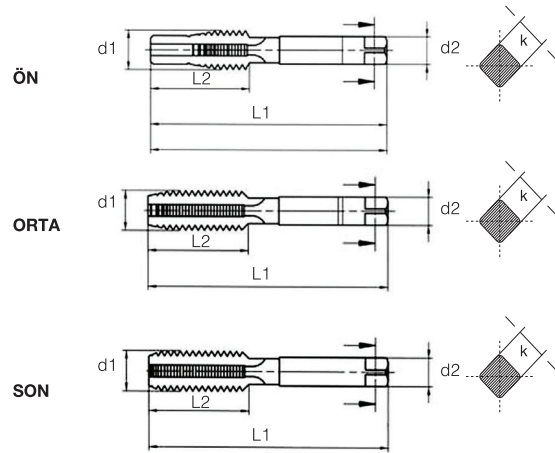

d1 mm	P adım	L1 mm	L2 mm	d2 mm	k (h12) mm
M2	0.4	40	8	2,8	2,1
M2,5	0.45	40	9	2,8	2,1
M3	0.5	40	11	3,5	2,7
M3,5	0.6	45	13	4,0	3,0
M4	0.7	45	13	4,5	3,4
M4.5	0.75	50	16	6,0	4,9
M5	0.8	50	16	6,0	4,9
M6	1	50	19	6,0	4,9
M7	1	50	19	6,0	4,9
M8	1.25	56	22	6,0	4,9
M9	1.25	63	22	7,0	5,5
M10	1.5	70	24	7,0	5,5
M11	1.5	70	24	8,0	6,2
M12	1.75	75	29	9,0	7,0
M14	2	80	30	11,0	9,0
M16	2	80	32	12,0	9,0
M18	2.5	95	40	14,0	11,0
M20	2.5	95	40	16,0	12,0
M22	2.5	100	40	18,0	14,5
M24	3	110	50	18,0	14,5
M27	3	110	50	20,0	16,0
M30	3.5	125	56	22,0	18,0
M33	3.5	125	56	25,0	20,0
M36	4	150	63	28,0	22,0
M39	4	150	63	32,0	24,0
M42	4.5	150	63	32,0	24,0
M45	4.5	160	70	36,0	29,0
M48	5	180	75	36,0	29,0

DÜZ KANALLI MAKİNA KLAVUZU
DIN 371/C HSS - E

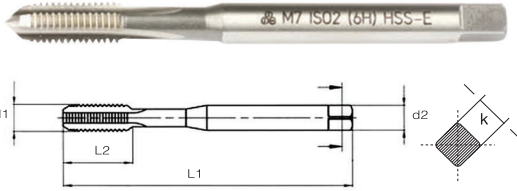

d1 mm	P adım	L1 mm	L2 mm	d2 mm	k (h12) mm
M3	0,5	56	10	3,5	2,7
M3,5	0,6	56	12	4,0	3,0
M4	0,7	63	12	4,5	3,4
M5	0,8	70	14	6,0	4,9
M6	1	80	16	6,0	4,9
M8	1,25	90	18	8,0	6,2
M10	1,5	100	20	10,0	8,0
M12	1,75	110	24	12,0	9,0

HELİS KANALLI MAKİNA KLAVUZU
DIN 371/C HSS - E

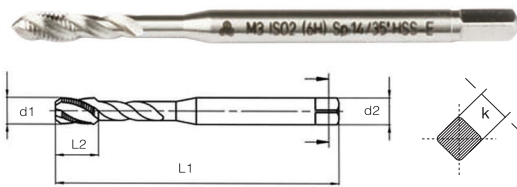

d1 mm	P adım	L1 mm	L2 mm	d2 mm	k (h12) mm
M3	0,5	56	6	3,5	2,7
M4	0,7	63	7	4,5	3,4
M5	0,8	70	8	6,0	4,9
M6	1	80	10	6,0	4,9
M8	1,25	90	12	8,0	6,2
M10	1,5	100	14	10,0	8,0
M12	1,75	110	16	12,0	9,0

DÜZ KANALLI MAKİNA KLAVUZU
DIN 376/C HSS - E

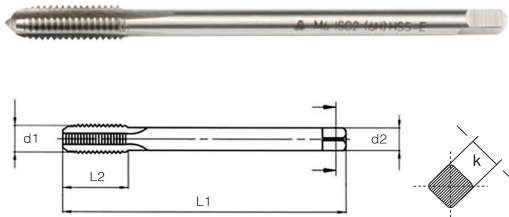

Tin Kaplamalı



d1 mm	P adım	L1 mm	L2 mm	d2 mm	k (h12) mm
M3	0,5	56	10	2,2	-
M4	0,7	63	12	2,8	2,1
M5	0,8	70	14	3,5	2,7
M6	1	80	16	4,5	3,4
M8	1,25	90	18	6,0	4,9
M9	1,25	90	18	7,0	5,5
M10	1,5	100	20	7,0	5,5
M11	1,5	100	20	8,0	6,2
M12	1,75	110	24	9,0	7,0
M14	2	110	26	11,0	9,0
M16	2	110	28	12,0	9,0
M18	2,5	125	30	14,0	11,0
M20	2,5	140	32	16,0	12,0
M22	2,5	140	32	18,0	14,5
M24	3	160	34	18,0	14,5
M27	3	160	38	20,0	16,0
M30	3,5	180	45	22,0	18,0

HELİS KANALLI MAKİNA KLAVUZU
DIN 376/C HSS - E

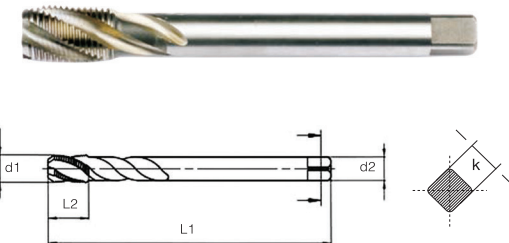

d1 mm	P adım	L1 mm	L2 mm	d2 mm	k (h12) mm
M3	0,5	56	10	2,2	-
M4	0,7	63	12	2,8	2,1
M5	0,8	70	14	3,5	2,7
M6	1	80	16	4,5	3,4
M8	1,25	90	18	6,0	4,9
M9	1,25	90	18	7,0	5,5
M10	1,5	100	20	7,0	5,5
M11	1,5	100	20	8,0	6,2
M12	1,75	110	24	9,0	7,0
M14	2	110	26	11,0	9,0
M16	2	110	28	12,0	9,0
M18	2,5	125	30	14,0	11,0
M20	2,5	140	32	16,0	12,0
M22	2,5	140	32	18,0	14,5
M24	3	160	34	18,0	14,5
M27	3	160	38	20,0	16,0
M30	3,5	180	45	22,0	18,0

İNCE DİŞ MAKİNA KLAVUZU
DIN 374/C HSS - E

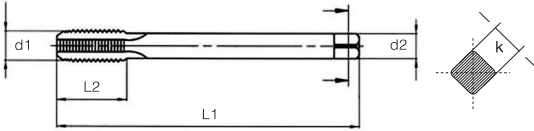

d1 mm	P adım	L1 mm	L2 mm	d2 mm	k (h12) mm
M6	0,75	80	14	4,5	3,4
M8	1	90	16	6,0	4,9
M10	1	90	20	7,0	5,5
M10	1,25	90	20	7,0	5,5
M12	1	100	22	9,0	7,0
M12	1,25	100	22	9,0	7,0
M12	1,5	100	22	9,0	7,0
M14	1	100	22	11,0	9,0
M14	1,25	100	22	11,0	9,0
M14	1,5	100	22	11,0	9,0
M16	1,5	100	22	12,0	9,0
M18	1,5	110	25	14,0	11,0
M20	1,5	125	25	16,0	12,0
M22	1,5	125	25	18,0	14,5
M24	1,5	140	28	18,0	14,5

UNC - DÜZ MAKİNA KLAVUZU
DIN 2183/C HSS - E

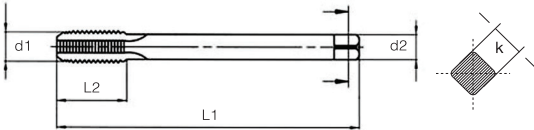

d1 mm	P adım	L1 mm	L2 mm	d2 mm	k (h12) mm
1/4"	20	80	19	4,5	3,4
5/16"	18	90	22	6,0	4,9
3/8"	16	100	24	7,0	5,5
7/16"	14	100	24	8,0	6,2
1/2"	13	110	29	9,0	7,0
9/16"	12	110	30	11,0	9,0
5/8"	11	110	32	12,0	9,0
3/4"	10	125	34	14,0	11,0
7/8"	9	140	34	18,0	14,5

UNF - DÜZ MAKİNA KLAVUZU
DIN 2183/C HSS - E



d1 mm	P adım	L1 mm	L2 mm	d2 mm	k (h12) mm
1/4"	28	80	19	4,5	3,4
5/16"	24	90	22	6,0	4,9
3/8"	24	100	24	7,0	5,5
7/16"	20	100	24	8,0	6,2
1/2"	20	110	29	9,0	7,0
9/16"	18	110	30	11,0	9,0
5/8"	18	110	32	12,0	9,0
3/4"	16	125	34	14,0	11,0
7/8"	14	140	34	18,0	14,5

WHITWORTH DÜZ MAKİNA KLAVUZU
DIN 2183/C HSS - E

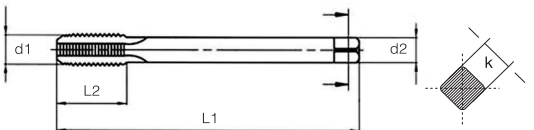

d1 mm	P adım	L1 mm	L2 mm	d2 mm	k (h12) mm
W 1/8"	40	56	11	3,5	2,7
W 5/32"	32	63	13	4,5	3,4
W 3/16"	24	70	16	6,0	4,9
W 7/32"	24	70	16	6,0	4,9
W 1/4"	20	80	19	6,0	4,9
W 5/16"	18	90	22	6,0	6,2
W 3/8"	16	100	24	10,0	8,0
W 7/16"	14	100	26	11,0	9,0
W 1/2"	12	110	28	12,0	9,0

SOMUN KLAVUZU
DIN 357 HSS

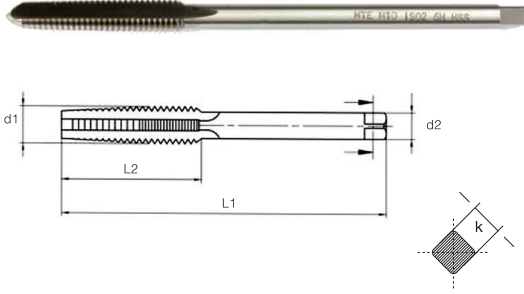

d1 mm	P adım	L1 mm	L2 mm	d2 mm	k (h12) mm
M3	0,5	70	22	2,2	-
M4	0,7	90	25	2,8	2,1
M5	0,8	100	28	3,5	2,7
M6	1	110	32	4,5	3,4
M8	1,25	125	40	6,0	4,9
M10	1,5	140	45	7,0	5,5
M12	1,75	180	50	9,0	7,0
M14	2	200	56	11,0	11,0
M16	2	200	63	12,0	12,0
M18	2,5	220	63	14,0	14,0
M20	2,5	250	70	16,0	16,0
M22	2,5	280	80	18,0	18,0
M24	3	280	80	18,0	18,0
M27	3	315	90	20,0	20,0

BORU VİDALI (G) DÜZ MAKİNA KLAVUZU
DIN 5156 C

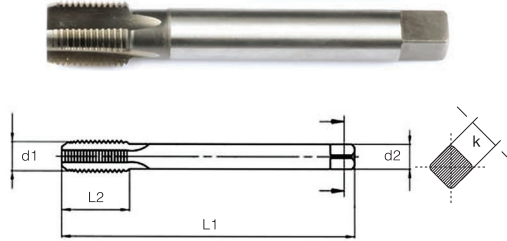

d1 mm	P adım	L1 mm	L2 mm	d2 mm	k (h12) mm
G 1/8"	28	90	20	7,0	5,5
G 1/4"	19	100	22	11,0	9,0
G 3/8"	19	100	22	12,0	9,0
G 1/2"	14	125	25	16,0	12,0
G 3/4"	14	140	28	20,0	16,0

ATLAMALI MAKİNA KLAVUZU
DIN 371 / C HSS - E

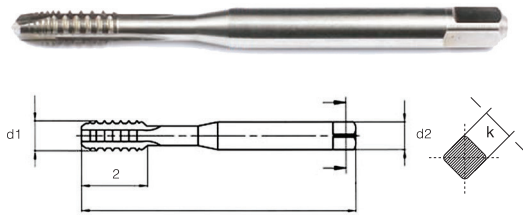

d1 mm	P adım	L1 mm	L2 mm	d2 mm	k (h12) mm
M3	0,5	56	10	3,5	2,7
M4	0,7	63	12	4,5	3,4
M5	0,8	70	14	6,0	4,9
M6	1	80	16	6,0	4,9
M8	1,25	90	18	8,0	6,2
M10	1,5	100	20	10,0	8,0
M12	1,75	110	24	12,0	9,0

ÖVALAMA MAKİNA KLAVUZU
DIN 371 / C HSS - E

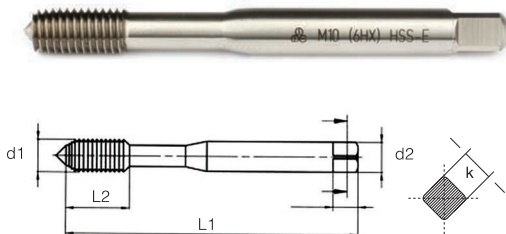

d1 mm	P adım	L1 mm	L2 mm	d2 mm	k (h12) mm
M3	0,5	56	10	3,5	2,7
M4	0,7	63	12	4,5	3,4
M5	0,8	70	14	6,0	4,9
M6	1	80	16	6,0	4,9
M8	1,25	90	18	8,0	6,2
M10	1,5	100	20	10,0	8,0
M12	1,75	110	24	12,0	9,0

YEŞİL HALKALI DÜZ MAKİNA KLAVUZU

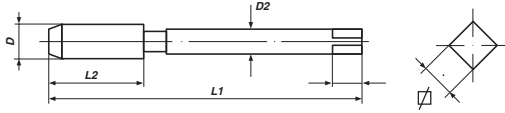

KOD	Ø D	D2	∅	L1	L2
35326	M3 x 0.5	3.5	2.7	56	11
35330	M4 x 0.7	4.5	3.4	63	13
35334	M5 x 0.8	6	4.9	70	16
35338	M6 x 1	6	4.9	80	19
35342	M8 x 1.25	8	6.2	90	22
35346	M10 x 1.5	10	8.0	100	24
35350	M12 x 1.75	9	7.0	110	29

BEYAZ HALKALI DÜZ MAKİNA KLAVUZU

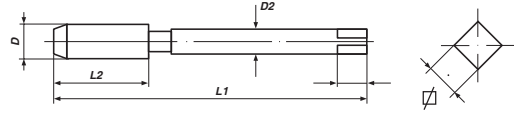

KOD	Ø D	D2	∅	L1	L2
35226	M3 x 0.5	3.5	2.7	56	11
35230	M4 x 0.7	4.5	3.4	63	13
35234	M5 x 0.8	6	4.9	70	16
35238	M6 x 1	6	4.9	80	19
35242	M8 x 1.25	8	6.2	90	22
35246	M10 x 1.5	10	8.0	100	24
35250	M12 x 1.75	9	7.0	110	29

OVALLAMA MAKİNA KLAVUZU

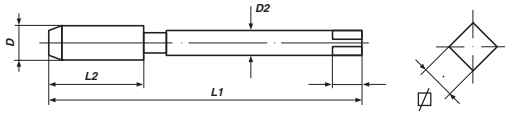

KOD	Ø D	D2	∅	L1	L2
35510	M3 x 0.5	3.5	2.7	56	11
35512	M4 x 0.7	4.5	3.4	63	13
35513	M5 x 0.8	6	4.9	70	16
35514	M6 x 1	6	4.9	80	19
35515	M8 x 1.25	8	6.2	90	22
35516	M10 x 1.5	10	8.0	100	24
35517	M12 x 1.75	9	7.0	110	29

MAVİ HALKALI DÜZ MAKİNA KLAVUZU

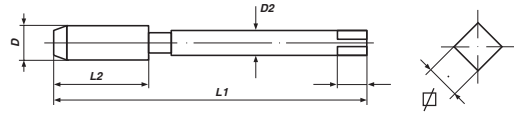

KOD	Ø D	D2	∅	L1	L2
35426	M3 x 0.5	3.5	2.7	56	11
35430	M4 x 0.7	4.5	3.4	63	13
35434	M5 x 0.8	6	4.9	70	16
35438	M6 x 1	6	4.9	80	19
35442	M8 x 1.25	8	6.2	90	22
35446	M10 x 1.5	10	8.0	100	24
35450	M12 x 1.75	9	7.0	110	29

TİTANYUM KAPLI DÜZ MAKİNA KLAVUZU

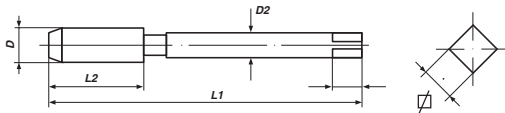

KOD	Ø D	D2	∅	L1	L2
31526	M3 x 0.5	3.5	2.7	56	11
31530	M4 x 0.7	4.5	3.4	63	13
31534	M5 x 0.8	6	4.9	70	16
31538	M6 x 1	6	4.9	80	19
31542	M8 x 1.25	8	6.2	90	22
31546	M10 x 1.5	10	8.0	100	24

SİYAH HALKALI DÜZ MAKİNA KLAVUZU

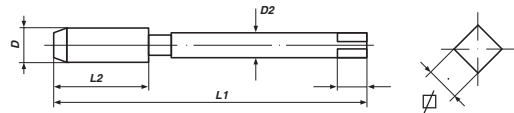

KOD	Ø D	D2	∅	L1	L2
35426	M3 x 0.5	3.5	2.7	56	11
35430	M4 x 0.7	4.5	3.4	63	13
35434	M5 x 0.8	6	4.9	70	16
35438	M6 x 1	6	4.9	80	19
35442	M8 x 1.25	8	6.2	90	22
35446	M10 x 1.5	10	8.0	100	24
35450	M12 x 1.75	9	7.0	110	29

PAFTA
DIN 223 / B HSS

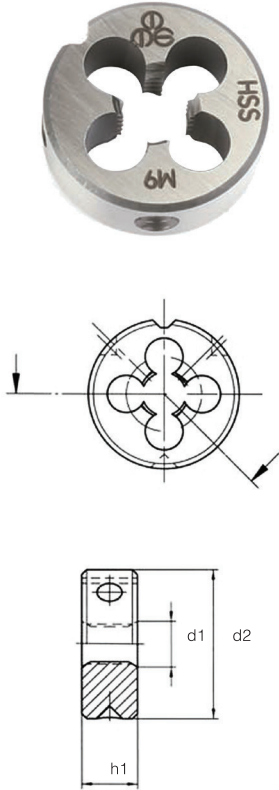

d1 mm	P adım	d2 mm	h1 mm
M2	0.4	16	5
M2,5	0.45	16	5
M3	0.5	20	5
M3,5	0.6	20	5
M4	0.7	20	5
M5	0.8	20	7
M6	1	20	7
M7	1	25	9
M8	1.25	25	9
M9	1.25	25	9
M10	1.5	30	11
M12	1.75	38	14
M14	2	38	14
M16	2	45	18
M18	2.5	45	18
M20	2.5	45	18
M22	2.5	55	22
M24	3	55	22
M27	3	65	25
M30	3.5	65	25
M33	3.5	65	25
M36	4	65	25
M39	4	75	30
M42	4.5	75	30
M45	4.5	90	36
M48	5	90	36
M52	5	90	36
M56	5.5	105	36
M60	5.5	105	36
M64	6	120	36
M68	6	120	36

PAFTA İNCE DİŞ
DIN 223 / B HSS

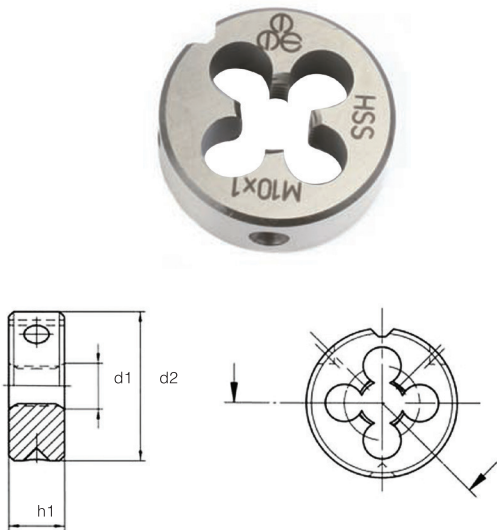

d1 mm	P adım	d2 mm	h1 mm
M 6	0.75	20	5
M 8	1	25	9
M 10	1	30	11
M 10	1.25	30	11
M 12	1	38	10
M 12	1.25	38	10
M 12	1.5	38	10
M 14	1	38	10
M 14	1.25	38	10
M 14	1.5	38	10
M 16	1	45	14
M 16	1.5	45	14
M 18	1.5	45	14
M 20	1.5	45	14
M 22	1.5	55	16
M 24	1.5	55	16
M 30	1.5	65	18

EL RAYBASI H7
DIN 206 / B HSS

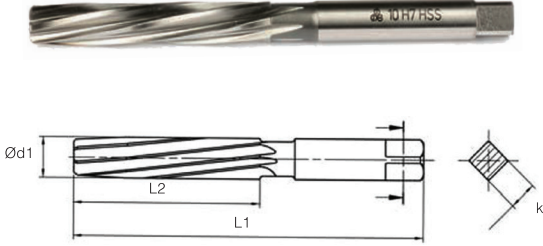

d1 mm	L1 mm	L2 mm	k mm
3,0	62	31	2,24
4,0	76	38	3,15
4,5	81	41	3,55
5,0	87	44	4,00
5,5	93	47	4,50
6,0	93	47	4,50
6,5	100	50	5,00
7,0	107	54	5,60
8,0	115	58	6,30
8,5	115	58	6,30
9,0	124	62	7,10
10,0	133	66	8,00
11,0	142	71	9,00
12,0	152	76	10,00
13,0	152	76	10,00
14,0	163	81	11,20
15,0	163	81	11,20
16,0	175	87	12,50
17,0	175	87	12,50
18,0	188	93	14,00
20,0	201	100	16,00
22,0	215	107	18,00
24,0	231	115	20,00
26,0	231	115	20,00
30,0	247	124	22,40
32,0	265	133	25,00
35,0	284	142	28,00
40,0	305	152	31,50

SİLİNDİR SAPLI MAKİNA RAYBASI H7
DIN 212 / D HSS

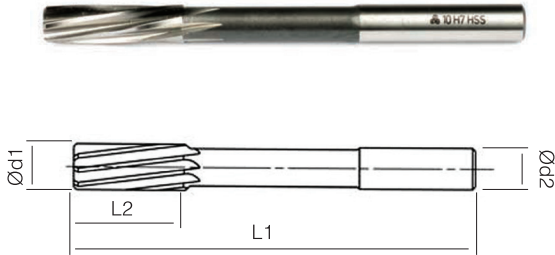

d1 mm	d2 (h9) mm	L1 mm	L2 mm
3	3,0	61	15
4	4,0	75	19
5	5,0	86	23
6	5,6	93	26
7	7,1	109	31
8	8,0	117	33
10	10,0	133	38
12	10,0	151	44
14	12,5	160	47
16	12,5	170	52
18	14,0	182	56
20	16,0	195	60

MORS KONİK SAPLI MAKİNA RAYBASI H7
DIN 208 / B HSS

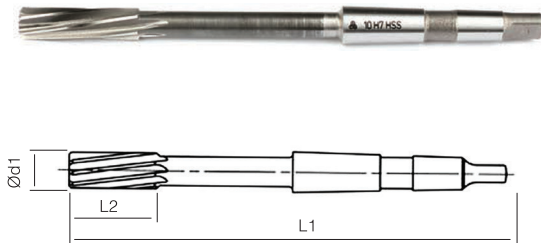

d1 mm	L1 mm	L2 mm	Mors Konik No
8	156	33	1
10	168	38	1
11	175	41	1
12	182	44	1
13	182	44	1
14	189	47	1
15	204	50	2
16	210	52	2
17	214	54	2
18	219	56	2
19	223	58	2
20	228	60	2
22	237	64	2
24	268	68	3
25	268	68	3
28	277	71	3
30	281	73	3
32	317	77	4
35	321	78	4
40	329	81	4
45	336	83	4
50	344	86	4

HAVŞA FREZESİ 90°
DIN 335 C HSS

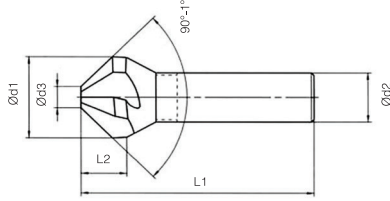

d1 mm	d2 mm	d3 mm	L1 mm	L2 mm
6,3	5,0	1,5	45	5,0
8,3	6,0	2	50	6,0
10,4	6,0	2,5	50	7,1
12,4	8,0	2,8	56	8,0
16,5	10,0	3,2	60	10,0
20,5	10,0	3,5	63	12,5
25,0	10,0	3,8	67	15,0
31,5	12,0	4,2	71	18,0

DELİKLİ HAVŞA FREZESİ 90°

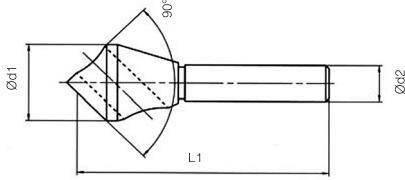

Çalışma Aralığı	d1 mm	d2 mm	L mm
2 - 5	10	6,0	45
5 - 10	14	8,0	48
10 - 15	21	10,0	65
15 - 20	28	12,0	85
20 - 25	35	12,7	102

PARMAK FREZE KISA
DIN 844 HSS - E Co. %8

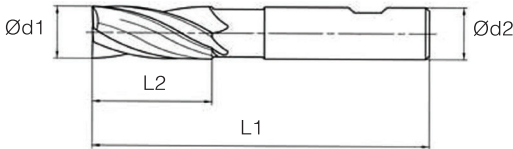

d1 mm	d2 mm	L1 mm	L2 mm	Z kanal sayısı
2,0	6	51	7	3
2,5	6	52	8	3
3,0	6	52	8	3
4,0	6	55	11	4
5,0	6	57	13	4
6,0	6	57	13	4
7,0	10	66	16	4
8,0	10	69	19	4
9,0	10	69	19	4
10,0	10	72	22	4
11,0	12	79	22	4
12,0	12	83	26	4
13,0	12	83	26	4
14,0	12	83	26	4
15,0	12	83	26	4
16,0	16	92	32	4
17,0	16	92	32	4
18,0	16	92	32	4
19,0	16	92	32	4
20,0	20	104	38	4
22,0	20	104	38	5
24,0	25	121	45	5
25,0	25	121	45	5
26,0	25	121	45	5
28,0	25	121	45	5
30,0	25	121	45	5
32,0	32	133	53	6
34,0	32	133	53	6
36,0	32	133	53	6
38,0	40	155	63	6
40,0	40	155	63	6

KABATALAŞ PARMAK FREZE KISA
DIN 844 HSS - E Co. %8

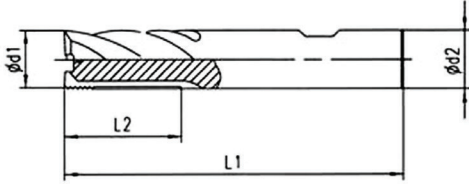

d1 mm	d2 mm	L1 mm	L2 mm	Z kanal sayısı
8,0	10	69	19	4
10,0	10	72	22	4
12,0	12	83	26	4
14,0	12	83	26	4
16,0	16	92	32	4
18,0	16	92	32	4
20,0	20	104	38	4
22,0	20	104	38	5
24,0	25	121	45	5
25,0	25	121	45	5
26,0	25	121	45	5
28,0	25	121	45	5
30,0	25	121	45	5
32,0	32	133	53	6

PARMAK FREZE UZUN
DIN 844 HSS - E Co. %8

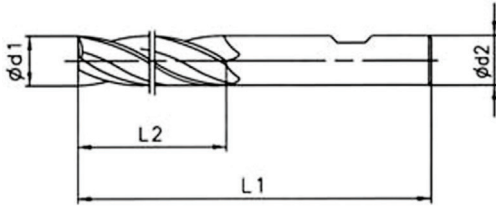

d1 mm	d2 mm	L1 mm	L2 mm	Z kanal sayısı
3	6	56	12	3
4	6	63	19	4
5	6	68	24	4
6	6	68	24	4
8	10	88	38	4
10	10	95	45	4
12	12	110	53	4
14	12	110	53	4
16	16	123	63	4
18	16	123	63	4
20	20	141	75	4
22	20	141	75	5
24	25	166	90	5
25	25	166	90	5
26	25	166	90	5
28	25	166	90	5
30	25	166	90	5
32	32	186	106	6
34	32	186	106	6
36	32	186	106	6
38	40	217	125	6
40	40	217	125	6

KABA TALAŞ PARMAK FREZE UZUN
DIN 844 HSS - E Co. %8

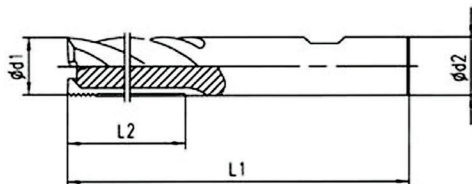

d1 mm	d2 mm	L1 mm	L2 mm	Z kanal sayısı
10	10	95	45	4
12	12	110	53	4
14	12	110	53	4
16	16	123	63	4
18	16	123	63	4
20	20	141	75	4
22	20	141	75	5
24	25	166	90	5
25	25	166	90	5
26	25	166	90	5
28	25	166	90	5
30	25	166	90	5
32	32	186	106	6

T YARIK FREZE
DIN 1833 / C HSS - E

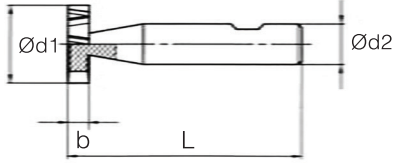

d1 mm	b (e8) mm	d2 mm	L1 mm
13,5	3	10	56
13,5	4	10	56
16,5	3	10	56
16,5	4	10	56
16,5	5	10	56
19,5	4	10	63
19,5	5	10	63
19,5	6	10	63
22,5	5	10	63
22,5	6	10	63
22,5	8	10	63
25,5	6	10	63
28,5	6	10	63
28,5	8	10	63
28,5	10	12	71
32,5	8	10	71
32,5	10	12	71
45,5	10	12	71

T YARIK FREZE
DIN 850 / D HSS - E



d1 mm	b mm	L mm	d2 mm	d1 mm	b mm	L mm	d2 mm
16 X 45°	4,0	60	12	16 X 60°	6,3	60	12
20 X 45°	5,0	63	12	20 X 60°	8,0	63	12
25 X 45°	6,3	67	12	25 X 60°	10,0	67	12
32 X 45°	8,0	71	16	32 X 60°	12,5	71	16

Muslukçu Raybası 1:10 Konik

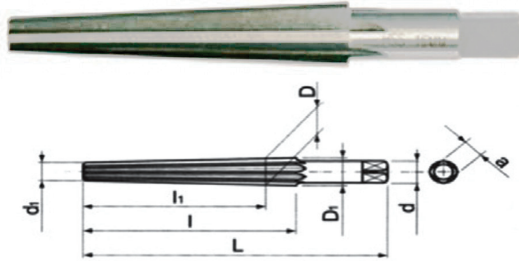

d ₁ (mm)	D (mm)	D ₁ (mm)	L (mm)	l (mm)	d (mm)	a (mm)
4	10.00	11	100	70	10.0	8
9	16.00	17	120	80	12.5	10
14	24.00	25	160	110	20.0	16
20	32.00	34	200	140	25.0	20

Pim Raybası 1:50 Konik

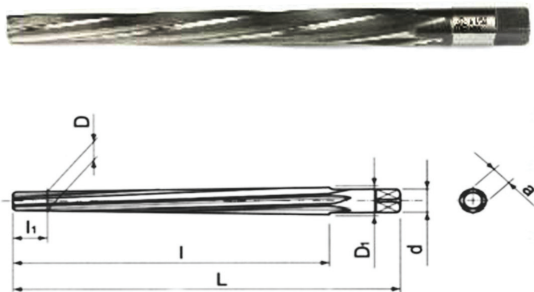

D (H7)	D ₁ (mm)	L (mm)	l (mm)	d (mm)	a (mm)
3	4.06	80	58	4.0	3.15
4	5.26	93	68	5.0	4.00
5	6.36	100	73	6.3	5.00
6	8.00	135	105	8.0	6.30
8	10.80	180	145	10.0	8.00
10	13.40	215	175	12.5	10.00
12	16.00	255	210	14.0	11.20
14	18.00	255	210	14.0	11.20
16	20.40	280	230	18.0	14.00
20	24.80	310	250	22.4	18.00
25	30.70	370	300	28.0	22.40
30	36.10	400	320	31.5	25.00

**SABİT PİLOTLU HAVŞA FREZESİ
(IMBUS FREZE)**

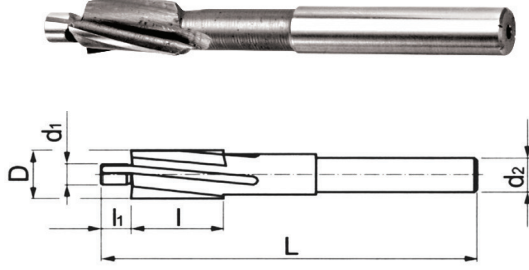

CİVATA	D (mm)	d ₁ (mm)	d ₂ (mm)	L (mm)	l (mm)	l1 (mm)
M3	6	3,2	5	71	14	4
M4	8	4,3	5	71	14	4
M5	10	5,3	8	80	18	6
M6	11	6,4	8	80	18	6
M8	15	8,4	12,5	100	22	8
M10	18	10,5	12,5	100	22	10
M12	20	13,0	12,5	100	22	12
M14	24	15,0	12,5	100	22	14
M16	26	17,0	12,5	100	22	16
M18	30	19,0	12,5	100	22	18
M20	33	20,0	12,5	100	22	20

KÖŞE YUVARLAMA FREZESİ



Plakaların köşelerine pah kırmak için kullanılır.

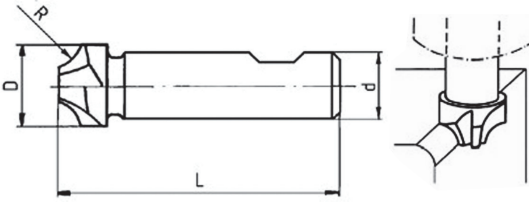

R H11	D js 16	L
1	8	60
1,5	10	60
1,6	10	60
2	10	60
2,5	10	60
3	12	60
3,5	14	60
4	14	60
4,5	15	60
5	16	60
5,5	21	67
6	21	67
6,5	24	71
7	24	71
7,5	24	71

R H11	D js 16	L
8	24	71
8,5	28	85
9	28	85
9,5	28	85
10	28	85
10,5	35	90
11	35	90
12	35	90
12,5	42	100
13	42	100
14	42	100
15	48	100
16	48	100
18	54	112
20	58	112

**AYARLI RAYBA
DÜZ - KOVANLI**

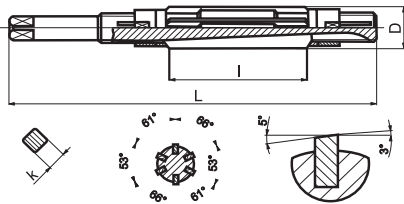

ÖLÇÜ (mm)	D (mm)	L (mm)	l (mm)	k (mm)	BIÇAK AD.
7,00-8,00	6	91	25	3	4
8,00-8,70	7	96	30	3,5	4
8,70-9,50	8	101	35	4	4
9,50-10,25	9	106	40	5	4
10,25-11,00	9,5	115	40	5	6
11,00-12,00	10	118	40	5	6
12,00-13,50	11	126	40	5	6
13,50-15,00	12	142	45	6	6
15,00-16,50	13	150	50	7	6
16,5-18,25	15	157	55	8	6
18,25-19,75	16	160	57	8	6
19,75-21,50	18	162	57	9	6
21,50-23,75	20	190	68	10	6
23,75-27,00	22	200	68	12	6
27,00-30,00	24	210	70	14	6
30,00-34,00	28	246	85	16	6
34,00-38,75	32	292	100	18	6
38,75-46,00	38	311	100	22	6
46,00-56,00	42	333	105	24	6

PANTORAF KALEMİ HSS - E (Co. %10)

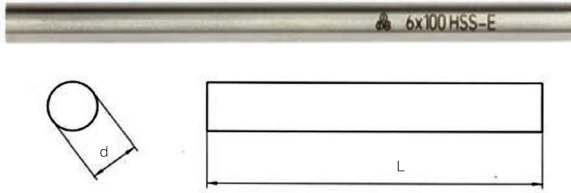

d1 mm	L mm	d1 mm	L mm
4	80	10	125
4	100	12	100
5	80	12	125
5	100	12	160
6	100	14	100
8	100	14	125
8	125	16	125
10	100	20	160

TORNA KALEMİ HSS - E (Co. %10)

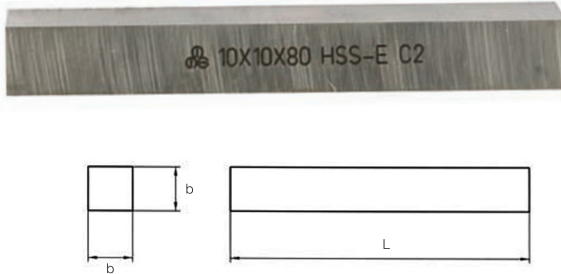

b mm	b mm	L mm	b mm	b mm	L mm
4	4	63	10	10	160
4	4	80	10	10	200
5	5	63	12	12	100
5	5	80	12	12	125
6	6	63	12	12	160
6	6	80	12	12	200
6	6	100	14	14	125
8	8	100	14	14	160
8	8	125	16	16	125
8	8	160	16	16	160
8	8	200	20	20	160
10	10	100	20	20	200
10	10	125			

TRAPEZ TORNA KALEMİ HSS - E (Co. %10)

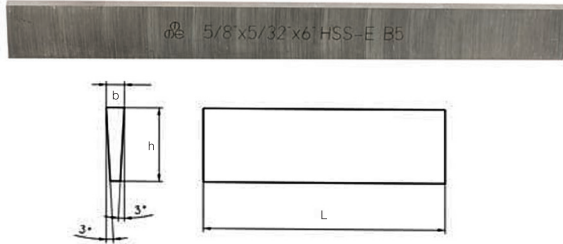

h Inch	b Inch	L Inch	h Inch	b Inch	L Inch
3/8"	3/32"	4"	7/8"	3/16"	6"
1/2"	1/8"	6"	7/8"	3/16"	8"
5/8"	5/32"	5"	1"	7/32"	6"
5/8"	5/32"	6"	1"	7/32"	8"
3/4"	3/16"	6"			

MANYETİK MATKAP UCU



Boy : 30 - 50 mm
Sap Çapı : 19 mm

Manyetik
Matkap Motoru



ÇAP	ÇAP	ÇAP	ÇAP
12 mm	25 mm	38 mm	51 mm
13 mm	26 mm	39 mm	52 mm
14 mm	27 mm	40 mm	53 mm
15 mm	28 mm	41 mm	54 mm
16 mm	29 mm	42 mm	55 mm
17 mm	30 mm	43 mm	56 mm
18 mm	31 mm	44 mm	57 mm
19 mm	32 mm	45 mm	58 mm
20 mm	33 mm	46 mm	59 mm
21 mm	34 mm	47 mm	60 mm
22 mm	35 mm	48 mm	
23 mm	36 mm	49 mm	
24 mm	37 mm	50 mm	

OTOMATİK KLAVUZ ÇEKME APARATI

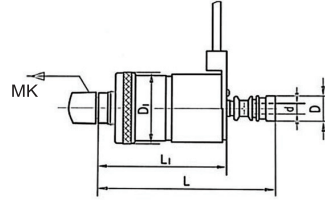

ÖLÇÜ	d(mm)	D (mm)	D ₁ (mm)	L (mm)	L ₁ (mm)	MK
M2-M7	2.5-6.5	23	55	135	95	MK2-MK3
M5-M12	3.5-10	28	75	164	114,5	MK3-MK4
M8-M20	6.3-14	38	90,5	205	135	MK3-MK4

KLAVUZ KOLU

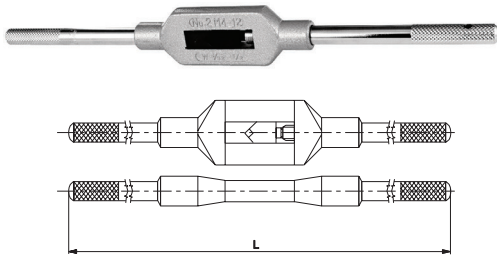

Kod	L (mm)	ÖLÇÜ
No 0	170	[M1 - M8]
No 1	200	[M1 - M12]
No 2	255	[M4 - M12]
No 3	345	[M5 - M20]
No 4	425	[M9 - M27]
No 5	765	[M13 - M32]
No 6	870	[M20 - M40]

CIRCIRLI KLAVUZ KOLU

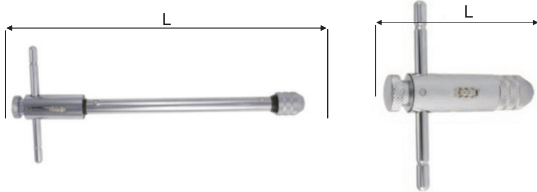

Kod	L (mm)	ÖLÇÜ (mm)
No 0	85	1 (M3 - M8)
No 1	110	2 (M5 - M12)
No 2	250	10 (M3 - M8)
No 3	310	20 (M5 - M12)

PAFTA KOLU

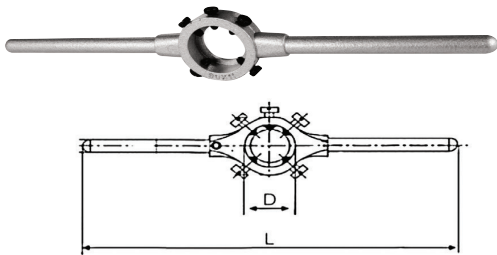

ÖLÇÜ	D (mm) × h1(mm)	L (mm)
M2 / M2,5	16 × 5	
M3 / M3,5 / M4	20 × 5	170
M5 / M6	20 × 7	170
M7 / M8 / M9	25 × 9	210
M10	30 × 11	270
M12 / M14	38 × 14	325
M16 / M18 / M20	45 × 18	400
M22 / M24	55 × 22	475
M27 / M30 / M33 / M36	65 × 25	555

TERS KLAVUZ SETİ



ADET	ÖLÇÜ
5 PARÇA	M3-M6/M6-M8/M8-M11/ M11-14/M14-M18
6 PARÇA	M3-M6/M6-M8/M8-M11/M11-14/ M14-M18/M18-24
8 PARÇA	M3-M6/M6-M8/M8-M11/M11-14/ M14-M18/M18-24/M24-M30/M30-M40

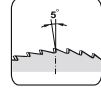
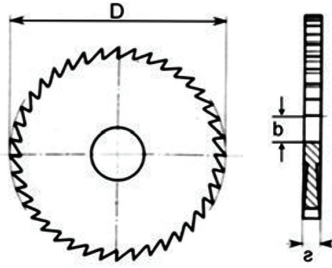
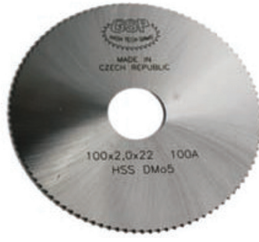



D x S	D	Z (Diş Sayısı)
25X0,4	8	48
25X0,6	8	48
25X1,0	8	48
25X1,2	8	48
25X1,5	8	48
25X1,6	8	48
25X2,0	8	48
32X1,0	8	48
32X1,2	8	48
32X1,5	8	48
32X1,6	8	48
32X2,0	8	48
32X4,0	8	32
32X5,0	8	32
40X0,2	10	128/160
40X0,25	10	100/160
40X0,3	10	100/160
40X0,4	10	128/160
40X0,5	10	80
40X0,6	10	80
40X0,7	10	80
40X0,8	10	80
40X0,9	10	80
40X1,0	10	64
40X1,2	10	64
40X1,5	10	64
40X1,6	10	64
40X2,0	10	48
40X2,5	10	48
40X3,0	10	48
50X0,2	13	128/200
50X0,25	13	128/200
50X0,3	10/13	128/160/200
50X0,4	13	100/200
50X0,5	13	100/200
50X0,6	13	100
50X0,7	13	100
50X0,8	13	80
50X0,9	13	80
50X1,0	13	80
50X1,2	13	80

D x S	D	Z (Diş Sayısı)
50X1,5	13	64
50X1,6	13	64
50X2,0	13	64
50X2,5	13	64
50X3,0	13	48
50X4,0	13	48
50X5,0	13	48
63X0,2	10/13/16	128/200
63X0,25	13/16	150/200
63X0,3	10/13/16	128/200
63X0,4	10/13/16	128/200
63X0,5	13/16	128/200
63X0,6	16	100
63X0,7	16	100
63X0,8	16	100
63X0,9	16	100
63X1,0	16	100
63X1,2	16	100
63X1,5	16	80
63X1,6	16	80
63X2,0	16	80
63X2,5	16	64
63X3,0	16	64
63X3,5	16	64
63X4,0	16	64
63X5,0	16	48
63X6,0	16	48
80X0,3	22	160
80X0,4	22	160
80X0,5	22	128
80X0,6	22	128
80X0,7	22	128
80X0,8	22	128
80X0,9	22	128
80X1,0	22	100
80X1,2	22	100
80X1,4	22	100
80X1,5	22	100
80X1,6	22	100
80X2,0	22	80
80X2,5	22	80

D x S	D	Z (Diş Sayısı)
80X3,0	22	80
80X3,5	22	80
80X4,0	22	64
80x5,0	22	64
80x6,0	22	64
100X0,5	22	160
100X0,6	22	160
100X0,7	22	160
100X0,8	22	128
100X0,9	22	128
100X1,0	22	128
100X1,2	22	128
100X1,5	22	128
100X1,6	22	100
100X2,0	22	100
100X2,5	22	100
100X3,0	22	80
100X3,5	22	80
100X4,0	22	80
100X5,0	22	80
100X6,0	22	64
125X0,6	22/27	160
125X0,8	22/27	160
125X1,0	22/27	160
125X1,2	22/27	128
125X1,5	22/27	128
125X1,6	22/27	128
125X2,0	22/27	64/128
125X2,5	22/27	64/100
125X3,0	22/27	100
125X3,5	22/27	100
125X4,0	22/27	100
125X5,0	22/27	80
125X6,0	22/27	80

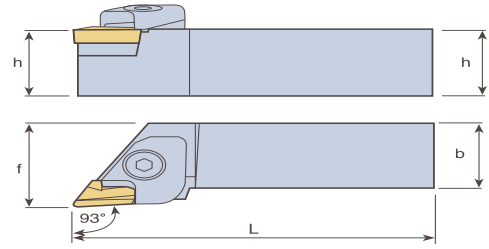
D x S	D	Z (Diş Sayısı)
160X1,0	32	160
160X1,2	32	80/100/160
160X1,4	32	80
160X1,6	32	80/100/160
160X2,0	32	128
160X2,5	32	128
160X3,0	32	128
160X3,5	32	64/128
160X4,0	32	64/100
160X5,0	32	100
160X6,0	32	100
200X1,0	32	100/200
200X1,2	32	100/200
200X1,5	32	160/200
200X1,6	32	100/160/200
200X2,0	32	80/160
200X2,5	32	160
200X3,0	32	128
200X3,5	32	128
200X4,0	32	128
200X4,5	32	128
200X5,0	32	128
200X6,0	32	100
250X2,0	32	200
250X2,5	32	160/200
250X3,0	32	160/200
250X4,0	32	160
250X5,0	32	160
275X3,0	32	160
275X4,0	32	160
275X5,0	32	160
300X3,0	32	160
300X4,0	32	160
300X5,0	32	160



Ürün Kodu	Ölçüler (mm)				Kullanılan Uç	Altlık
	h	b	L	f		
CKJNR/L 2020 K 16	20	20	125	25	 KNUX 16 04..	 AKS - 16 - R AKS - 16 - L
CKJNR/L 2525 M 16	25	25	150	32		
CKJNR/L 3232 P 16	32	32	170	40		
CKJNR/L 4040 S 16	40	40	250	50		

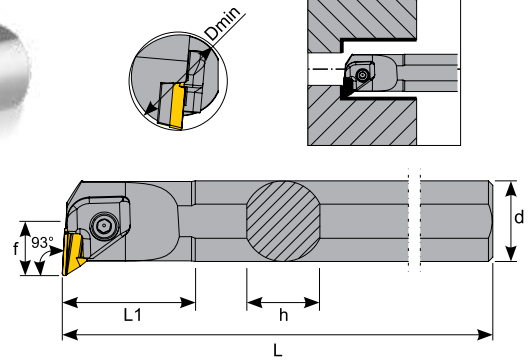

Sipariş Kodu	Ürün Kodu	Ölçüler (mm)						Kullanılan Uç
		Dmin	d	L	L1	f	h	
RK 750	S25S CKUNR 16	32	25	250	52	17	23	 KNUX 16 04..
RK 752	S28T CKUNR 16	35	28	300	52	19	25	
RK 754	S32U CKUNR 16	40	32	350	52	22	29	
RK 756	S40V CKUNR 16	50	40	400	55	27	37	
RK 758	S45V CKUNR 16	54	45	400	60	29	43	
RK 760	S50W CKUNR 16	63	50	450	60	35	47	

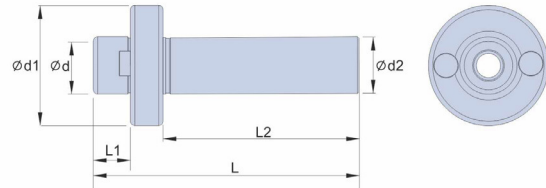



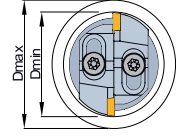
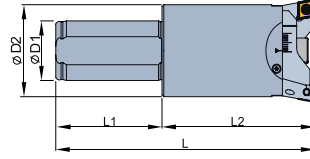

Sipariş Kodu	Ürün Kodu	Ölçüler (mm)					
		d	d1	d2	L	L1	L2
M300	16 - 25	16	38	25	95	15	60
M302	22 - 25	22	47	25	97	17	60
M304	27 - 25	27	59	25	97	20	60
M306	32 - 25	32	65	25	98	23	60

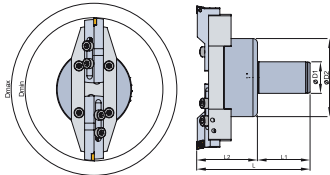

SİPARİŞ KODU	ÜRÜN KODU	ÖLÇÜLER (mm)						
		Dmin	Dmax	ØD1	ØD2	L	L1	L2
TKB 088	16-20 L100	16	20	16	16	100	50	50
TKB 090	16-20 L150	16	20	16	16	150	50	100
TKB 092	16-20 L200	16	20	16	16	200	50	150
TKB 094	19-23 L100	19	23	16	16	100	50	50
TKB 096	19-23 L150	19	23	16	16	150	50	100
TKB 098	19-23 L200	19	23	16	16	200	50	150
TKB 100	23-28 L100	23	28	20	20	100	50	50
TKB 102	23-28 L150	23	28	20	20	150	50	100
TKB 104	23-28 L230	23	28	20	20	230	50	180
TKB 106	28-38 L105	28	38	20	25	105	50	55
TKB 108	28-38 L155	28	38	20	25	155	50	105
TKB 110	23-38 L230	28	38	20	25	230	50	180
TKB 112	37-48 L120	37	48	25	32	120	55	65
TKB 114	37-48 L170	37	48	25	32	170	55	115
TKB 116	37-48 L255	37	48	25	32	255	55	200
TKB 118	45-56 L126	45	56	32	40	126	60	66
TKB 120	45-56 L176	45	56	32	40	176	60	116
TKB 122	45-56 L260	45	56	32	40	260	60	200
TKB 124	55-75 L145	55	75	32	50	145	60	85
TKB 126	55-75 L195	55	75	32	50	195	60	135
TKB 128	55-75 L280	55	75	32	50	280	60	220
TKB 130	70-90 L145	70	90	32	63	145	60	85
TKB 132	70-90 L195	70	90	32	63	195	60	135
TKB 134	70-90 L280	70	90	40	63	280	60	220
TKB 136	90-130 L175	90	130	32	75	175	60	115
TKB 138	90-130 L225	90	130	32	75	225	60	165

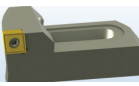
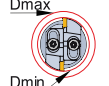

KOLLU HASSAS BARA TAKIMLARI

KARTUŞLAR	Dmin-Dmax	KULLANILAN UÇ	SIKMA CİVATASI	SABİTLEME CİVATASI
				
KR 100	23-28	CC □ □ 0602	TC 060 M2.5	M5x25
KR 102	28-38	CC □ □ 09T3	TC 070 M3.5	M5x25
KR 104	37-48	CC □ □ 09T3	TC 070 M3.5	M6x30
KR 106	45-56	CC □ □ 09T3	TC 070 M3.5	M8x30
KR 108	55-75	CC □ □ 09T3	TC 070 M3.5	M8x30
KR 110	70-90	CC □ □ 09T3	TC 070 M3.5	M8x30
KR 112	90-130	CC □ □ 09T3	TC 070 M3.5	M8x30
KR 114	120-170	CC □ □ 09T3	TC 070 M3.5	M8x30
KR 120	170-250	CC □ □ 09T3	TC 070 M3.5	M8x30
KR 122	240-350	CC □ □ 09T3	TC 070 M3.5	M8x30

SİPARİŞ KODU	ÜRÜN KODU	ÖLÇÜLER (mm)				KULLANILAN UÇ
		ØD	Ød	Z	H	
T176	D040-16 Z05 AP10	40	16	5	40	AP □ □ 1003
T177	D050-22 Z06 AP10	50	22	6	40	
T178	D063-22 Z07 AP 10	63	22	7	40	
T179	D080-32 Z08 AP 10	80	32	8	50	
T180	D040-16 Z03 AP16	40	16	3	45	AP □ □ 1604
T181	D040-16 Z04 AP16	40	16	4	45	
T182	D050-22 Z04 AP16	50	22	4	45	
T183	D050-22 Z05 AP16	50	22	5	45	
T184	D063-22 Z05 AP16	63	22	5	45	
T185	D063-22 Z06 AP16	63	22	6	45	
T186	D080-32 Z06 AP16	80	32	6	52	
T187	D080-32 Z07 AP16	80	32	7	52	
T188	D100-32 Z07 AP16	100	32	7	52	
T189	D100-32 Z08 AP16	100	32	8	52	
T190	D125-40 Z09 AP16	125	40	9	62	
T192	D160-40 Z10 AP16	160	40	10	62	

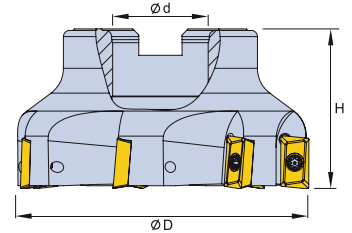

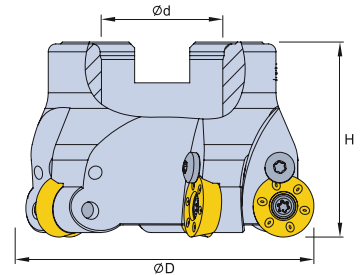

SİPARİŞ KODU	ÜRÜN KODU	ÖLÇÜLER (mm)				KULLANILAN UÇ
		ØD	Ød	Z	H	
T288	D040-16 Z03 RD10	40	16	3	40	RD □ □ 1003
T289	D040-16 Z04 RD10	40	16	4	40	
T290	D050-22 Z04 RD10	50	22	4	40	
T291	D050-22 Z05 RD10	50	22	5	40	
T292	D063-22 Z05 RD10	63	22	5	40	
T293	D063-22 Z06 RD10	63	22	6	40	
T294	D080-32 Z06 RD10	80	32	6	50	
T294-1	D080-32 Z07 RD10	80	32	7	50	
T295	D100-32 Z07 RD10	100	32	7	50	
T295-1	D100-32 Z08 RD10	100	32	8	50	
T280	D040-16 Z03 RD12	40	16	3	40	RD □ □ 12T3
T281	D040-16 Z04 RD12	40	16	4	40	
T282	D050-22 Z04 RD12	50	22	4	40	
T283	D050-22 Z05 RD12	50	22	5	40	
T284	D063-22 Z05 RD12	63	22	5	40	
T285	D063-22 Z06 RD12	63	22	6	40	
T286	D080-32 Z06 RD12	80	32	6	50	
T286-1	D080-32 Z07 RD12	80	32	7	50	
T287	D100-32 Z07 RD12	100	32	7	50	
T287-1	D100-32 Z08 RD12	100	32	8	50	
T296	D063-22 Z04 RD16	63	22	4	45	RD □ □ 1605
T297	D080-32 Z05 RD16	80	32	5	50	
T298	D100-32 Z06 RD16	100	32	6	50	



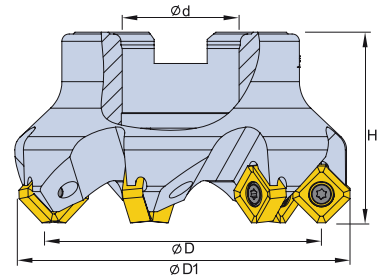



SİPARİŞ KODU	ÜRÜN KODU	ÖLÇÜLER (mm)					KULLANILAN UÇ
		ØD	ØD1	Ød	Z	H	
T300	D063-22 Z05 SD12	63	76	22	5	45	 SD □□ 1204
T302	D080-32 Z06 SD12	80	93	32	6	52	
T304	D100-32 Z07 SD12	100	113	32	7	60	
T305	D125-40 Z07 SD12	125	40	7	62		

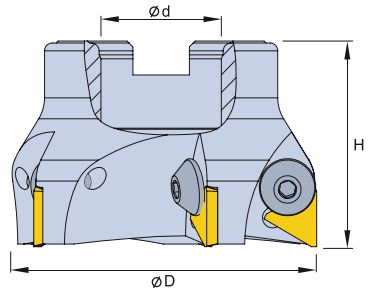
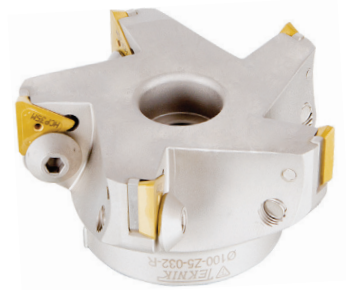

SİPARİŞ KODU	ÜRÜN KODU	ÖLÇÜLER (mm)						KULLANILAN UÇ
		ØD	Ød	Z	H	E		
T114	D042-16 Z03 TP16	42	16	3	44	--	 TPKN 1603	
T116	D050-22 Z03 TP16	50	22	3	44	--		
T118	D063-22 Z03 TP16	63	22	3	44	--		
T120	D063-22 Z04 TP16	63	22	4	44	--		
T122	D080-32 Z05 TP16	80	32	5	52	--		
T124	D100-32 Z06 TP16	100	32	6	52	--		
T126	D063-22 Z03 TP22	63	22	3	50	--	 TPKN 2204	
T128	D080-32 Z04 TP22	80	32	4	52	--		
T130	D100-32 Z05 TP22	100	32	5	52	--		
T132	D125-40 Z06 TP22	125	40	6	62	--		
T134	D160-40 Z07 TP22	160	40	7	62	66.7		
T136	D200-60 Z08 TP22	200	60	8	62	101.6		
T138	D250-60 Z09 TP22	250	60	9	62	101.6		



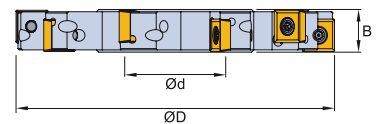
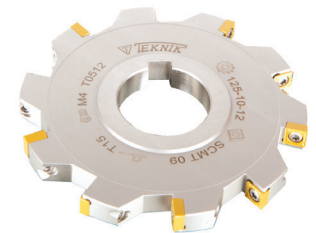

SİPARİŞ KODU	ÜRÜN KODU	ÖLÇÜLER (mm)						KULLANILAN UÇ
		ØD	Ød	Z	Ap	A	B	
DF 100	125-Z10-10-SC09	125	40	10	32	10	10.5	 SCMT 09
DF 102	125-Z10-12-SC09	125	40	10	32	10	12.5	
DF 104	125-Z10-16-SC12	125	40	10	32	16	16.5	 SCMT 12
DF 106	125-Z10-20-SC12	125	40	10	32	20	20.5	
DF 110	160-Z12-12-SC09	160	40	12	50	12	12.5	 SCMT 09
DF 112	160-Z12-16-SC12	160	40	12	50	16	16.5	
DF 114	160-Z12-20-SC12	160	40	12	50	20	20.5	 SCMT 12





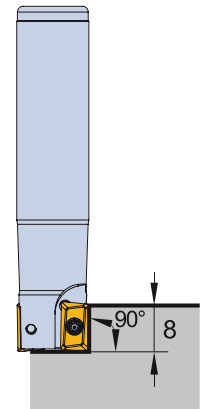
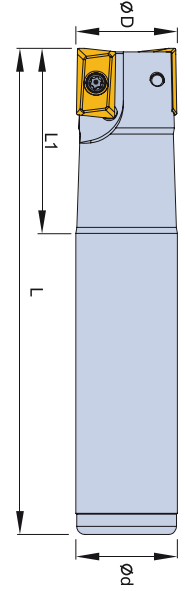



SİPARİŞ KODU	ÜRÜN KODU	ÖLÇÜLER (mm)					KULLANILAN UÇ
		ØD	Ød	Z	L	L1	
S136	12-01-100-AP10	12	12	1	100	27	APKT 1003
S138	14-01-100-AP10	14	14	1	100	27	
S140	16-02-100-AP10	16	16	2	100	30	
S142	18-02-100-AP10	18	16	2	100	30	
S144	20-03-100-AP10	20	20	3	100	30	
S146	22-03-100-AP10	22	20	3	100	30	
S148	25-03-100-AP10	25	25	3	100	35	
S150	30-04-100-AP10	30	25	4	100	35	
S152	32-04-100-AP10	32	25	4	100	35	
S154	35-04-100-AP10	35	25	4	100	35	
S156	40-05-100-AP10	40	25	5	100	35	
S158	12-01-120-AP10	12	12	1	120	27	
S160	14-01-120-AP10	14	14	1	120	30	
S162	16-02-120-AP10	16	16	2	120	40	
S164	18-02-120-AP10	18	16	2	120	40	
S166	20-03-120-AP10	20	20	3	120	40	
S168	22-03-120-AP10	22	20	3	120	40	
S169	25-03-120-AP10	25	25	3	120	40	
S170	30-04-120-AP10	30	25	4	120	40	
S171	35-04-120-AP10	35	25	4	120	40	
S172	40-05-120-AP10	40	25	5	120	40	
S173	16-02-150-AP10	16	16	2	150	50	
S174	18-02-150-AP10	18	16	2	150	50	
S176	20-03-150-AP10	20	20	3	150	60	
S178	22-03-150-AP10	22	20	3	150	60	
S180	25-03-150-AP10	25	25	3	150	60	
S180-1	30-04-150-AP10	30	25	4	150	60	
S181	32-04-150-AP10	32	25	4	150	60	
S182	16-02-200-AP10	16	16	2	200	60	
S184	18-02-200-AP10	18	16	2	200	60	
S186	20-03-200-AP10	20	20	3	200	60	
S187	22-03-200-AP10	22	20	3	200	70	
S188	25-03-200-AP10	25	25	3	200	60	
S188-1	30-04-200-AP10	30	25	4	200	50	
S189	32-03-200-AP10	32	32	4	200	60	
S190	16-02-250-AP10	16	16	2	250	70	
S192	20-03-250-AP10	20	20	3	250	70	
S194	25-03-250-AP10	25	25	3	250	70	

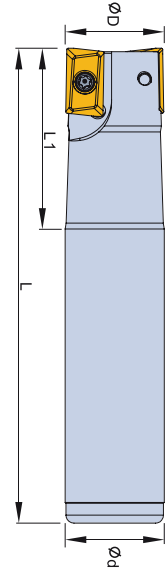

SİPARİŞ KODU	ÜRÜN KODU	ÖLÇÜLER (mm)					KULLANILAN UÇ
		ØD	Ød	Z	L	L1	
S256	25-02-120-AP16	25	25	2	120	45	 <p>APKT 1604</p>
S258	30-02-120-AP16	30	25	2	120	45	
S260	32-03-120-AP16	32	25	3	120	45	
S262	35-03-120-AP16	35	25	3	120	45	
S264	40-04-120-AP16	40	25	4	120	45	
S266	25-02-150-AP16	25	25	2	150	55	
S268	30-02-150-AP16	30	25	2	150	55	
S270	32-03-150-AP16	32	25	3	150	55	
S272	35-03-150-AP16	35	25	3	150	55	
S274	40-04-150-AP16	40	25	4	150	55	
S276	25-02-200-AP16	25	25	2	200	55	
S278	30-02-200-AP16	30	25	2	200	55	
S280	32-03-200-AP16	32	25	3	200	55	
S282	35-03-200-AP16	35	32	3	200	55	
S283	40-04-200-AP16	40	32	4	200	55	
S432	25-02-250-AP16	25	25	2	250	60	
S434	30-02-250-AP16	30	25	2	250	60	
S436	32-03-250-AP16	32	32	3	250	60	
S438	35-03-250-AP16	35	32	3	250	60	
S440	40-04-250-AP16	40	32	4	250	60	
S442	25-02-300-AP16	25	25	2	300	70	
S444	30-02-300-AP16	30	25	2	300	70	
S446	32-03-300-AP16	32	32	3	300	70	
S448	35-03-300-AP16	35	32	3	300	70	
S450	40-04-300-AP16	40	32	4	300	70	
S453	32-03-350-AP16	32	32	3	350	70	
S454	35-03-350-AP16	35	32	3	350	70	
S456	40-04-350-AP16	40	32	4	350	70	



SİPARİŞ KODU	ÜRÜN KODU	ÖLÇÜLER (mm)					KULLANILAN UÇ
		ØD	Ød	Z	L	L1	
S116	22-02-120-TP11	22	20	2	120	45	 <p>TPKN 1103</p>
S118	25-02-120-TP11	25	25	2	120	45	
S120	28-02-120-TP11	28	25	2	120	45	
S122	30-03-120-TP11	30	25	3	120	45	
S124	32-03-120-TP11	32	25	3	120	45	
S126	35-03-120-TP11	35	25	3	120	45	
S128	35-02-120-TP16	35	25	2	120	45	 <p>TPKN 1603</p>
S130	40-03-120-TP16	40	25	3	120	45	
S132	45-03-120-TP16	45	25	3	120	45	
S134	50-03-120-TP22	50	32	3	120	55	 <p>TPKN 2204</p>

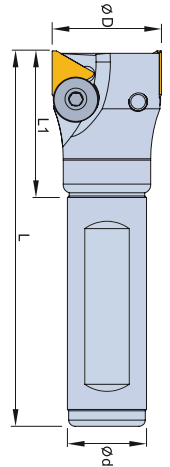

SİPARİŞ KODU	ÜRÜN KODU	ÖLÇÜLER (mm)					KULLANILAN UÇ
		ØD	Ød	Z	L	L1	
R162	16-02-120-RD08	16	16	2	120	50	RD □ □ 0803
R164	18-02-120-RD08	18	16	2	120	50	
R166	20-03-120-RD08	20	20	3	120	50	
R168	16-02-150-RD08	16	16	2	150	60	
R170	18-02-150-RD08	18	16	2	150	60	
R172	20-03-150-RD08	20	20	3	150	60	
R174	16-02-200-RD08	16	16	2	200	70	
R176	18-08-200-RD08	18	16	2	200	70	
R178	20-03-200-RD08	20	20	3	200	70	
R190	20-02-120-RD10	20	20	2	120	40	RD □ □ 1003
R192	25-03-120-RD10	25	25	3	120	40	
R193	30-03-120-RD10	30	25	3	120	40	
R194	32-03-120-RD10	32	25	3	120	40	
R196	35-03-120-RD10	35	25	3	120	40	
R198	40-03-120-RD10	40	25	3	120	40	
R200	20-02-150-RD10	20	20	2	150	60	
R202	25-03-150-RD10	25	25	3	150	60	
R203	30-03-150-RD10	30	25	3	150	60	
R204	32-03-150-RD10	32	25	3	150	60	
R206	35-03-150-RD10	35	25	3	150	60	
R208	40-03-150-RD10	40	25	3	150	60	
R210	20-02-200-RD10	20	20	2	200	70	
R212	25-03-200-RD10	25	25	3	200	70	
R213	30-03-200-RD10	30	25	3	200	70	
R214	32-03-200-RD10	32	32	3	200	70	
R216	35-03-200-RD10	35	32	3	200	70	
R218	40-03-200-RD10	40	32	3	200	70	
R228	25-02-120-RD12	25	25	2	120	40	RD □ □ 12T3
R229	30-02-120-RD12	30	25	2	120	40	
R230	32-03-120-RD12	32	25	3	120	40	
R232	35-03-120-RD12	35	25	3	120	40	
R234	40-03-120-RD12	40	25	3	120	40	
R236	25-02-150-RD12	25	25	2	150	60	
R237	30-02-150-RD12	30	25	2	150	60	
R238	32-03-150-RD12	32	25	3	150	60	
R240	35-03-150-RD12	35	25	3	150	60	
R242	40-03-150-RD12	40	25	3	150	60	
R244	25-02-200-RD12	25	25	2	200	70	
R245	30-02-200-RD12	30	25	2	200	70	
R246	32-03-200-RD12	32	32	3	200	70	
R248	35-03-200-RD12	35	32	3	200	70	
R250	40-03-200-RD12	40	32	3	200	70	
R251	40-03-250-RD12	40	32	3	250	70	
R252	50-04-250-RD12	50	32	4	250	70	
R254	25-02-300-RD12	25	25	2	300	70	
R255	30-02-300-RD12	30	25	2	300	70	
R256	32-03-300-RD12	32	32	3	300	70	
R258	35-03-300-RD12	35	32	3	300	70	
R259	40-03-300-RD12	40	32	3	300	70	
R260	35-03-350-RD12	35	32	3	350	70	
R261	40-03-350-RD12	40	32	3	350	70	
R270	40-03-300-RD16	40	32	3	300	70	RD □ □ 1604
R272	50-03-300-RD16	50	32	3	300	70	



RD □ □ 0803



RD □ □ 1003



RD □ □ 12T3

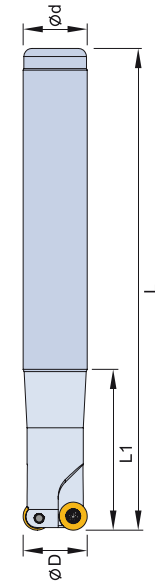

Küre Saplı Tarama Başlığı

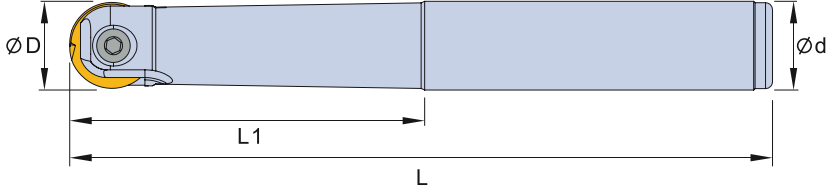

SİPARİŞ KODU	ÜRÜN KODU	ÖLÇÜLER (mm)				KULLANILAN UÇ
		ØD	Ød	L	L1	
S370	08-10-130	8	10	130	50	P3201 D08
S372	10-12-130	10	12	130	60	P3201 D10
S374	12-12-150	12	12	150	70	P3201 D12
S376	16-16-175	16	16	175	80	P3201 D16
S378	20-20-200	20	20	200	100	P3201 D20
S380	25-25-200	25	25	200	100	P3201 D25
S381	30-32-200	30	32	200	90	P3201 D30
S382	32-32-200	32	32	200	90	P3201 D32



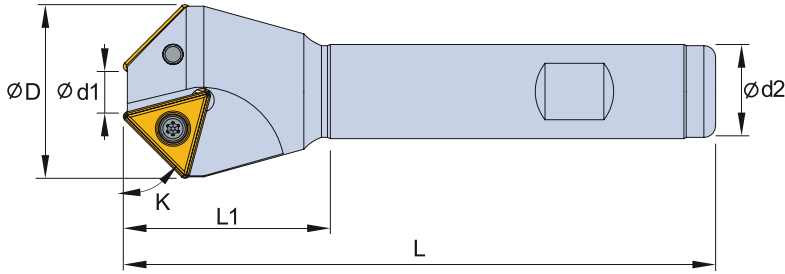

Açılı Saplı Tarama Başlığı



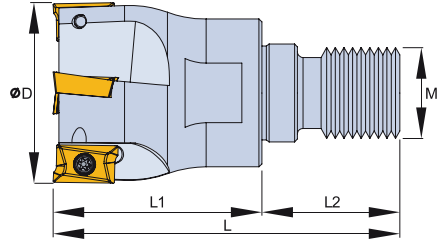
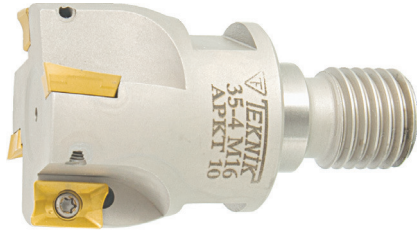

SİPARİŞ KODU	ÜRÜN KODU	ÖLÇÜLER (mm)							KULLANILAN UÇ
		ØD	Ød1	Ød2	Z	L	L1	K	
S335	02-16-Z2-TC11	16	2	16	2	100	35	30°	TCMT 1102
S334	04-15-Z1-TC11	15	4	16	1	100	35	45°	
S339	10-31-Z2-TC16	31	10	16	2	100	35	30°	
S336	10-31-Z2-TC16	31	10	16	2	100	35	45°	TCMT 16T3
S338	14-35-Z2-TC16	35	14	20	2	100	35	45°	
S340	22-43-Z3-TC16	43	22	25	3	100	35	45°	
S342	32-53-Z3-TC16	53	32	25	3	100	35	45°	
S343	24-39-Z2-TC16	39	24	20	2	100	35	60°	





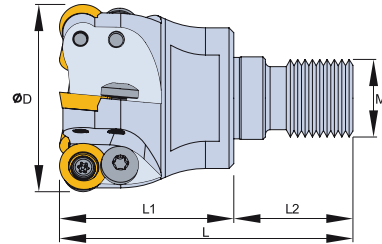
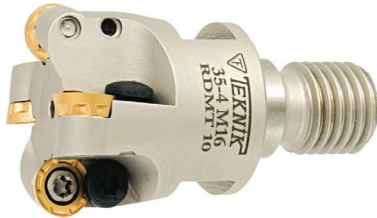

SİPARİŞ KODU	ÜRÜN KODU	ÖLÇÜLER (mm)						KULLANILAN UÇ
		ØD	M	Z	L	L1	L2	
VT 138	20-03-M10-AP10	20	M10	3	55	38	17	 APKT 1003
VT 140	25-03-M12-AP10	25	M12	3	55	33	22	
VT 143	32-04-M16-AP10	32	M16	4	60	36	24	
VT 146	35-04-M16-AP10	35	M16	4	60	36	24	
VT 148	40-05-M16-AP10	40	M16	5	60	36	24	
VT 150	42-05-M16-AP10	42	M16	5	60	36	24	 APKT 1604
VT 160	25-02-M12-AP16	25	M12	2	55	33	22	
VT 163	32-03-M16-AP16	32	M16	3	60	36	24	
VT 166	35-03-M16-AP16	35	M16	3	60	36	24	
VT 168	40-04-M16-AP16	40	M16	4	60	36	24	
VT 170	42-04-M16-AP16	42	M16	4	60	36	24	



SİPARİŞ KODU	ÜRÜN KODU	ÖLÇÜLER (mm)						KULLANILAN UÇ
		ØD	M	Z	L	L1	L2	
VT 098	20-02-M10-RD10	20	M10	2	55	35	20	 RDMT 1003
VT 100	25-03-M12-RD10	25	M12	3	55	33	22	
VT 103	32-03-M16-RD10	32	M16	3	60	36	24	
VT 106	35-04-M16-RD10	35	M16	4	60	36	24	
VT 108	40-05-M16-RD10	40	M16	5	60	36	24	
VT 110	42-05-M16-RD10	42	M16	5	60	36	24	 RDMT 12T3
VT 120	25-02-M12-RD12	25	M12	2	55	33	22	
VT 123	32-03-M16-RD12	32	M16	3	60	36	24	
VT 126	35-03-M16-RD12	35	M16	3	60	36	24	
VT 128	40-04-M16-RD12	40	M16	4	60	36	24	
VT 130	42-04-M16-RD12	42	M16	4	60	36	24	
VT 132	45-04-M16-RD12	45	M16	4	60	36	24	

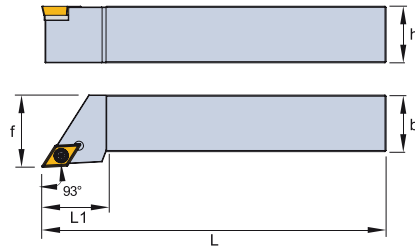

93° SDJC - SDJCL



SİPARİŞ KODU	ÜRÜN KODU	ÖLÇÜLER (mm)					KULLANILAN UÇ	ALTLIK
		L	L1	h	f	b		
D220	SDJCR 1010 J07	110	12	10	10	10	 DC □ □ 0702 DCMT 11T3 DCMT 11T3	 ---- ---- TA 030
D222	SDJCR 1212 J11	110	18	12	12	12		
D224	SDJCR 1616 H11	100	24	16	20	16		
D226	SDJCR 2020 K11	125	24	20	25	20		
D228	SDJCR 2525 M11	150	30	25	32	25		
D360	SDJCL 1010 J07	110	12	10	10	10		
D362	SDJCL 1212 J11	110	18	12	12	12		
D364	SDJCL 1616 H11	100	24	16	20	16		
D366	SDJCL 2020 K11	125	24	20	25	20		
D368	SDJCL 2525 M11	150	30	25	32	25		

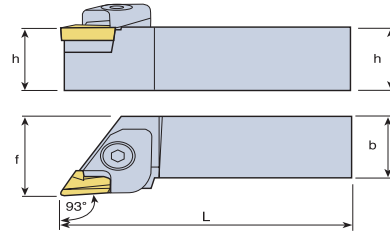

93° CKJNR R-L



ÜRÜN KODU	ÖLÇÜLER (mm)				KULLANILAN UÇ	ALTLIK
	h	b	L	f		
CKJNR/L 2020 K 16	20	20	125	25	 KNUX 16 04..	 AKS-16-R AKS-16-L
2525 M16	25	25	150	32		
3232 P 16	32	32	170	40		
4040 S 16	40	40	250	50		

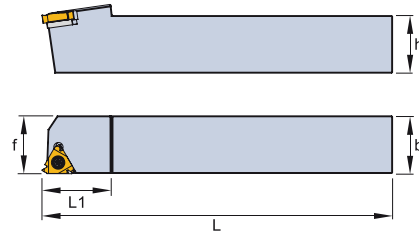





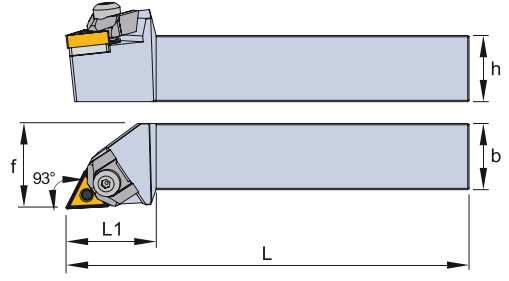

Diş Çap Diş Kateri R-L



SİPARİŞ KODU	ÜRÜN KODU	ÖLÇÜLER (mm)					KULLANILAN UÇ	ALTLIK
		L	L1	h	f	b		
D261	AL 12-3	110	20	12	12	12	 16 ER 22 ER 16 ER 16 ER	 TA 044 ---- TA 044 TA 044
D259	AL 16-3	100	22	16	16	16		
D258	AL 20-3	125	25	20	20	20		
D260	AL 25-3	150	30	25	25	25		
D266	AL 25-4	150	36	25	25	25		
D262	AL 32-3	170	30	32	32	32		
D268	AL 20-3 SOL	125	25	20	20	20		
D269	AL 25-3 SOL	150	30	25	25	25		





93° DDJNR - DDJNL

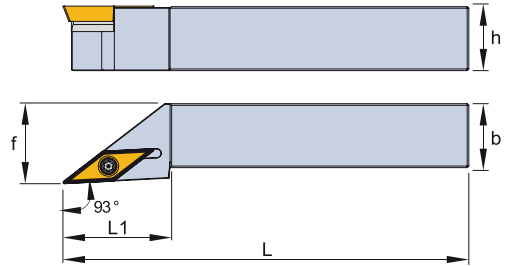

SİPARİŞ KODU	ÜRÜN KODU	ÖLÇÜLER (mm)					KULLANILAN UÇ	ALTLIK	BASKI
		L	L1	h	f	b			
D167	DDJNR 2020 K11	125	35	20	25	20	 DN □ □ 1104 DN □ □ 1506	 TA 030 TA 014	 BK 021 BK 020
D168	DDJNR 2525 M11	150	35	25	32	25			
D170	DDJNR 2020 K15	125	38	20	25	20			
D172	DDJNR 2525 M15	150	38	25	32	25	 DN □ □ 1104 DN □ □ 1506	 TA 030 TA 014	 BK 021 BK 020
D174	DDJNR 3232 P15	170	38	32	40	32			
D307-1	DDJNL 2020 K11	125	35	20	25	20			
D308	DDJNL 2525 M11	150	35	25	32	25	 DN □ □ 1104 DN □ □ 1506	 TA 030 TA 014	 BK 021 BK 020
D310	DDJNL 2020 K15	125	38	20	25	20			
D312	DDJNL 2525 M15	150	38	25	32	25			
D314	DDJNL 3232 P15	170	38	32	40	32			

93° SVJBR - SVJBL



SİPARİŞ KODU	ÜRÜN KODU	ÖLÇÜLER (mm)					KULLANILAN UÇ	ALTLIK
		L	L1	h	f	b		
D230	SVJBR 1010 J11	110	21	10	10	10	 VB □ □ 1103 VBMT 1604	 ---- TA 034
D232	SVJBR 1212 J11	110	21	12	12	12		
D234	SVJBR 1616 H11	110	21	16	16	16		
D235	SVJBR 1616 H16	100	27	16	20	16		
D236	SVJBR 2020 K16	125	33	20	25	20		
D238	SVJBR 2525 M16	150	39	25	32	25		
D370	SVJBL 1010 J11	110	21	10	10	10	 VB □ □ 1103 VBMT 1604	 ---- TA 034
D372	SVJBL 1212 J11	110	21	12	12	12		
D373	SVJBL 1616 H11	110	21	16	16	16		
D374	SVJBL 1616 H16	100	27	16	20	16		
D380	SVJBL 2020 K16	125	33	20	25	20		
D382	SVJBL 2525 M16	150	39	25	32	25		

SİPARİŞ KODU	ÜRÜN KODU	ÖLÇÜLER (mm)						KULLANILAN UÇ	
		Dmin	d	L	L1	f	h		
K100	S06-08H SCLCR 06	8	8	100	25	4.3	7	 CC □ □ 0602	
K102	S08H SCLCR 06	11	8	100	20	5.5	7		
K104	S10J SCLCR 06	13	10	110	20	6	9		
K105	S10K SCLCR 06	13	10	125	20	6	9		
K106	S12K SCLCR 06	16	12	125	24	9	11		
K107	S12Q SCLCR 06	16	12	180	24	9	11		
K108	S14-16Q SCLCR 09	19	16	180	45	10	15		
K110	S16Q SCLCR 09	20	16	180	30	11	15		
K111	S16R SCLCR 09	20	16	200	30	11	15		
K112	S18-20Q SCLCR 09	24	20	180	37	12	18		
K114	S20Q SCLCR 09	25	20	180	37	13	18		
K115	S20S SCLCR 09	25	20	250	37	13	18		
K116	S25R SCLCR 09	32	25	200	40	17	23		
K117	S25T SCLCR 09	32	25	300	40	17	23		
K230	S06-08H SCLCL 06	8	8	100	25	7	7		CC □ □ 09T3
K232	S08H SCLCL 06	11	8	100	20	7	7		
K234	S10J SCLCL 06	13	10	110	20	9	9		
K236	S12K SCLCL 06	16	12	125	24	11	11		
K238	S14-16Q SCLCL 09	19	16	180	45	15	15		
K240	S16Q SCLCL 09	20	16	180	30	15	15		
K241	S16R SCLCL 09	20	16	200	30	15	15		
K244	S20Q SCLCL 09	25	20	180	37	18	18		
K245	S20S SCLCL 09	25	20	250	37	18	18		
K246	S25R SCLCL 09	32	25	200	40	23	23		

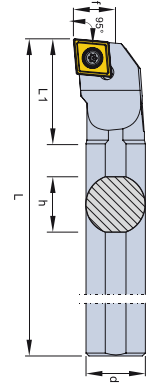

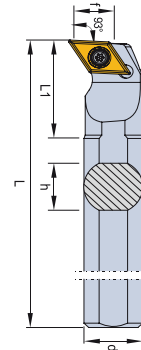

SİPARİŞ KODU	ÜRÜN KODU	ÖLÇÜLER (mm)						KULLANILAN UÇ
		Dmin	d	L	L1	f	h	
K120	S10J SDUCR 07	14	10	110	20	7	9	 DC □ □ 0702
K122	S12K SDUCR 07	17	12	125	24	9	11	
K124	S14-16Q SDUCR 07	20	16	180	40	10.5	15	
K126	S16Q SDUCR 07	21	16	180	27	11	15	
K125	S14-16Q SDUCR 11	20	16	180	45	10.5	15	
K128	S16Q SDUCR 11	21	16	180	30	11	15	
K130	S20Q SDUCR 11	25	20	180	32	13	18	
K132	S25R SDUCR 11	32	25	200	40	17	23	
K134	S32T SDUCR 11	40	32	300	45	22	30	
K250	S10J SDUCL 07	14	10	110	20	7	9	
K252	S12K SDUCL 07	17	12	125	24	9	11	
K254	S14-16Q SDUCL 07	20	16	180	40	10.5	15	
K256	S16Q SDUCL 07	21	16	180	27	11	15	
K258	S16Q SDUCL 11	21	16	180	30	11	15	
K260	S20Q SDUCL 11	25	20	180	32	13	18	
K262	S25R SDUCL 11	32	25	200	40	17	23	
K263	S32T SDUCL 11	40	32	300	45	22	30	





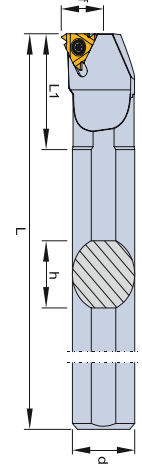

SİPARİŞ KODU	ÜRÜN KODU	ÖLÇÜLER (mm)						KULLANILAN UÇ
		Dmin	d	L	L1	f	h	
K348	S10J STIR 11	12	10	110	20	6	7	 11 IR
K350	S12K STIR 11	14	12	125	24	7.2	11	
K352	S16Q STIR 16	20	16	180	40	11	15	
K354	S20Q STIR 16	24	20	180	40	13	18	
K356	S25R STIR 16	29	25	200	40	16	23	
K358	S32T STIR 16	36	32	300	40	19.5	30	
K359	S25R STIR 22	32	25	200	40	17	23	
K360	S32T STIR 22	39	32	300	40	22	30	
K360-1	S40T STIR 22	50	40	300	60	24.5	38	
K361	S16Q STIL 16	20	16	180	40	11	15	
K362	S20Q STIL 16	24	20	180	40	13	18	
K363	S25R STIL 16	29	25	200	40	16	23	



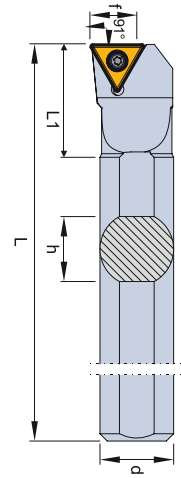



SİPARİŞ KODU	ÜRÜN KODU	ÖLÇÜLER (mm)						KULLANILAN UÇ
		Dmin	d	L	L1	f	h	
K160	S12K STFCR 11	17	12	125	24	9	11	 TCMT 1102 TCMT 16T3
K161	S16Q STFCR 11	21	16	180	30	11	15	
K162	S16Q STFCR 16	21	16	180	30	11	15	
K164	S20Q STFCR 16	25	20	180	30	13	18	
K166	S25R STFCR 16	32	25	200	37	16	23	

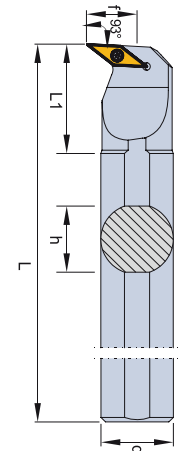

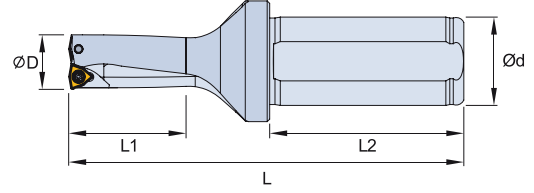



SİPARİŞ KODU	ÜRÜN KODU	ÖLÇÜLER (mm)						KULLANILAN UÇ
		Dmin	d	L	L1	f	h	
K206	S16Q SVUBR 11	21	16	180	30	11	15	 VBMT 1103 VBMT 1604
K207	S20Q SVUBR 11	25	20	180	30	13	18	
K208	S25R SVUBR 16	32	25	200	40	17	23	
K209	S32T SVUBR 16	40	32	300	50	22	30	
K210	S40T SVUBR 16	49	40	300	55	27	38	



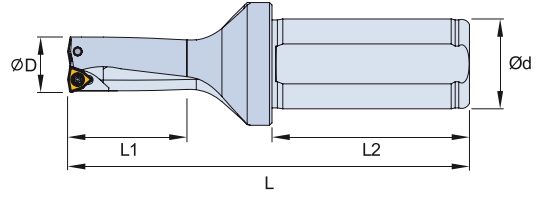

SİPARİŞ KODU	ÜRÜN KODU	ÖLÇÜLER (mm)						KULLANILAN UÇ	
		D	d	d1	L	L1	L2		
U104	D2 16 WCMX 03	16	25	34	115	32	55	 WCMX 0302	
U105	D2 17 WCMX 03	17	25	34	118	34	55		
U106	D2 18 WCMX 03	18	25	34	120	36	55		
U107	D2 19 WCMX 03	19	25	34	123	38	55		
U108	D2 20 WCMX 04	20	25	34	125	40	55	WCMX 0402	
U110	D2 21 WCMX 04	21	25	34	129	42	55		
U112	D2 22 WCMX 04	22	25	34	131	44	55		
U114	D2 23 WCMX 04	23	25	34	134	46	55		
U116	D2 24 WCMX 05	24	25	34	136	48	55	WCMX 0503	
U118	D2 25 WCMX 05	25	25	34	138	50	55		
U120	D2 26 WCMX 05	26	25	34	147	52	55		
U122	D2 27 WCMX 05	27	25	34	149	54	55		
U124	D2 28 WCMX 05	28	25	34	152	56	55		
U126	D2 29 WCMX 05	29	25	34	154	58	55		
U128	D2 30 WCMX 06	30	32	44	156	60	58	 WCMX 06T3	
U130	D2 31 WCMX 06	31	32	44	161	62	58		
U132	D2 32 WCMX 06	32	32	44	163	64	58		
U134	D2 33 WCMX 06	33	32	44	165	66	58		
U136	D2 34 WCMX 06	34	32	44	168	68	58		
U137	D2 35 WCMX 06	35	32	44	170	70	58		
U138	D2 36 WCMX 06	36	32	44	172	72	58		
U139	D2 37 WCMX 06	37	32	44	174	74	58		
U140	D2 38 WCMX 06	38	32	44	176	76	58		
U141	D2 39 WCMX 06	39	32	44	178	78	58		
U142	D2 40 WCMX 06	40	32	44	180	80	58		
U143	D3 16 WCMX 03	16	25	34	131	48	55		WCMX 0302
U144	D3 17 WCMX 03	17	25	34	135	51	55		
U146	D3 18 WCMX 03	18	25	34	138	54	55		
U148	D3 19 WCMX 03	19	25	34	142	57	55		
U150	D3 20 WCMX 04	20	25	34	145	60	55	WCMX 0402	
U152	D3 21 WCMX 04	21	25	34	150	63	55		
U154	D3 22 WCMX 04	22	25	34	153	66	55		
U156	D3 23 WCMX 04	23	25	34	157	69	55		
U158	D3 24 WCMX 05	24	25	34	160	72	55	WCMX 0503	
U160	D3 25 WCMX 05	25	25	34	163	75	55		
U162	D3 26 WCMX 05	26	25	34	173	78	55		
U164	D3 27 WCMX 05	27	25	34	176	81	55		
U166	D3 28 WCMX 05	28	25	34	180	84	55		
U168	D3 29 WCMX 05	29	25	34	183	87	55		
U170	D3 30 WCMX 06	30	32	44	186	90	58	 WCMX 06T3	
U172	D3 31 WCMX 06	31	32	44	192	93	58		
U174	D3 32 WCMX 06	32	32	44	195	96	58		
U176	D3 33 WCMX 06	33	32	44	198	99	58		
U178	D3 34 WCMX 06	34	32	44	202	102	58		
U179	D3 35 WCMX 06	35	32	44	205	105	58		
U180	D3 36 WCMX 06	36	32	44	208	108	58		
U181	D3 37 WCMX 06	37	32	44	211	111	58		



SİPARİŞ KODU	ÜRÜN KODU	ÖLÇÜLER (mm)						KULLANILAN UÇ	
		D	d	d1	L	L1	L2		
U182	D3 38 WCMX 06	38	32	44	214	114	58	 WCMX 06T3	
U183	D3 39 WCMX 06	39	32	44	217	117	58		
U184	D3 40 WCMX 06	40	32	44	220	120	58		
U186	D3 41 WCMX 06	41	32	49	220	123	58		
U188	D3 42 WCMX 06	42	32	49	220	126	58		
U190	D3 43 WCMX 06	43	32	49	225	129	58		
U192	D3 44 WCMX 06	44	32	49	225	132	58		
U194	D3 45 WCMX 06	45	32	49	225	135	58		
U196	D3 46 WCMX 08	46	40	59	230	138	68		 WCMX 0804
U198	D3 47 WCMX 08	47	40	59	230	141	68		
U200	D3 48 WCMX 08	48	40	59	230	144	68		
U201	D3 49 WCMX 08	49	40	59	235	147	68		
U202	D3 50 WCMX 08	50	40	59	235	150	68		
U203	D3 51 WCMX 08	51	40	59	235	153	68		
U205	D3 52 WCMX 08	52	40	59	245	156	68		
U207	D3 53 WCMX 08	53	40	59	245	159	68		
U209	D3 54 WCMX 08	54	40	59	245	162	68		
U211	D3 55 WCMX 08	55	40	59	255	165	68		
U600	D4 16 WCMX 03	16	25	34	139	64	55	WCMX 0302	
U602	D4 17 WCMX 03	17	25	34	143	68	55		
U604	D4 18 WCMX 03	18	25	34	148	72	55		
U606	D4 19 WCMX 03	19	25	34	152	76	55		
U608	D4 20 WCMX 04	20	25	34	158	80	55	WCMX 0402	
U610	D4 21 WCMX 04	21	25	34	162	84	55		
U612	D4 22 WCMX 04	22	25	34	166	88	55		
U614	D4 23 WCMX 04	23	25	34	171	92	55		
U616	D4 24 WCMX 05	24	25	34	175	96	55	WCMX 0503	
U618	D4 25 WCMX 05	25	25	34	180	100	55		
U620	D4 26 WCMX 05	26	25	34	184	104	55		
U622	D4 27 WCMX 05	27	25	34	189	108	55		
U624	D4 28 WCMX 05	28	25	34	194	112	55		
U626	D4 29 WCMX 05	29	25	34	198	116	55		
U628	D4 30 WCMX 06	30	32	44	209	120	58	 WCMX 06T3	
U631	D4 31 WCMX 06	31	32	44	215	124	58		
U632	D4 32 WCMX 06	32	32	44	219	128	58		
U633	D4 33 WCMX 06	33	32	44	223	132	58		
U634	D4 34 WCMX 06	34	32	44	227	136	58		
U635	D4 35 WCMX 06	35	32	44	231	140	58		
U636	D4 36 WCMX 06	36	32	44	235	144	58		
U637	D4 37 WCMX 06	37	32	44	239	148	58		
U638	D4 38 WCMX 06	38	32	44	241	152	58		
U639	D4 39 WCMX 06	39	32	44	245	156	58		
U640	D4 40 WCMX 06	40	32	44	250	160	58		

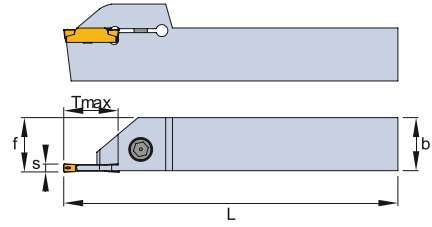

SİPARİŞ KODU	ÜRÜN KODU	ÖLÇÜLER (mm)						KULLANILAN UÇ
		L	Tmax	h	b	f	s	
D658	1212 2C-R JD KORLOY	125	16	12	12	12	2	2C JD KORLOY
D660	1616 2C-R JD KORLOY	125	16	16	16	16	2	
D662	2020 2C-R JD KORLOY	125	16	20	20	20	2	
D664	2525 2C-R JD KORLOY	150	16	25	25	25	2	
D666	3232 2C-R JD KORLOY	170	18	32	32	32	2	
D667	1212 3C-R JD KORLOY	125	18	12	12	12	3	
D668	1616 3C-R JD KORLOY	125	18	16	16	16	3	
D670	2020 3C-R JD KORLOY	125	18	20	20	20	3	
D672	2525 3C-R JD KORLOY	150	18	25	25	25	3	4C JD KORLOY
D674	3232 3C-R JD KORLOY	170	20	32	32	32	3	
D675	1616 4C-R JD KORLOY	125	18	16	16	16	4	
D676	2020 4C-R JD KORLOY	125	18	20	20	20	4	5C JD KORLOY
D678	2525 4C-R JD KORLOY	150	18	25	25	25	4	
D680	3232 4C-R JD KORLOY	170	20	32	32	32	4	
D682	2020 5C-R JD KORLOY	125	18	20	20	20	5	6C JD KORLOY
D684	2525 5C-R JD KORLOY	150	24	25	25	25	5	
D686	3232 5C-R JD KORLOY	170	24	32	32	32	5	
D687	2525 6C-R JD KORLOY	150	24	25	25	25	6	6C JD KORLOY
D687-1	3232 6C-R JD KORLOY	170	24	32	32	32	6	

İç Çap Kanal Kateri

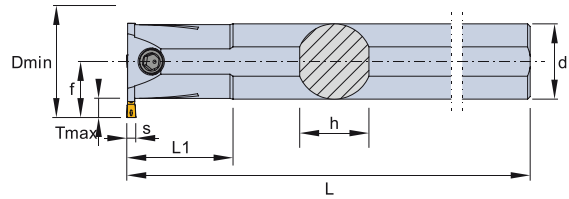



















SİPARİŞ KODU	ÜRÜN KODU	ÖLÇÜLER (mm)								KULLANILAN UÇ
		Dmin	Tmax	L	L1	d	h	f	s	
K600	S16Q 2C JD KORLOY	20	4.90	180	35	16	15	12.5	2	2C JD KORLOY
K602	S20Q 2C JD KORLOY	25	5.70	180	35	20	18	15.5	2	
K603	S25R 2C JD KORLOY	31	5.70	200	35	25	23	18.6	2	
K604	S20Q 3C JD KORLOY	25	6	180	35	20	18	15.8	3	
K606	S25R 3C JD KORLOY	31	6.70	200	40	25	23	19	3	
K608	S32S 3C JD KORLOY	37	6.70	250	45	32	30	21.5	3	
K609	S40T 3C JD KORLOY	45	7.40	300	60	40	38	27	3	3C JD KORLOY
K610	S20Q 4C JD KORLOY	25	6	180	35	20	18	15.8	4	
K612	S25R 4C JD KORLOY	31	6	200	40	25	23	19	4	
K614	S32S 4C JD KORLOY	37	6	250	65	32	30	21.5	4	4C JD KORLOY
K616	S40T 4C JD KORLOY	45	7.40	300	60	40	38	27	4	
K618	S25R 5C JD KORLOY	31	7	200	40	25	23	19.4	5	
K620	S32S 5C JD KORLOY	37	7	250	60	32	30	21.5	5	5C JD KORLOY
K622	S40T 5C JD KORLOY	45	7.40	300	60	40	38	27	5	

TORK CİVATALAR / Torx Screws

							
TC 090 M1.6 T6	TC 051 M1.8 T6 / 54 Ncm	TC 058 M2 T6 / 65 Ncm	TC 059 M2.2x5 T7 / 85 Ncm	TC 060 M2.2x5.5 T8 / 130 Ncm	TC 063 M2.5x7 T8 / 135 Ncm	TC 065 M3x7 T8 / 235 Ncm	TC 066 M3x10 T8 / 240 Ncm
							
TC 068 M3.5x6 T15 / 140 Ncm	TC 070 M3.5x8.5 T15 / 350 Ncm	TC 072 M3.5x11 T15 / 355 Ncm	TC 074 M4x10 (K.BAŞLI) T15 / 500 Ncm	TC 075 M4x10 (K.BAŞLI) T15 / 500 Ncm	TC 078 M4x11 (B.BAŞLI) T15 / 520 Ncm	TC 080 M4.5x11 T15 / 760 Ncm	TC 083 M5x12 T20 / 1050 Ncm

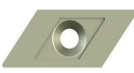
ALTIKLAR / Underlay Plate

						
TA 010 TPKN 16	TA 012 TPKN 22	TA 014 DNMG 15	TA 015 CCMT 09	TA 016 CNMG 12	TA 017 CNMG 19	TA 018 TNMG 16
						
TA 019 MTJNR	TA 020 WNMG 08	TA 021 WNMG 06	TA 022 CNMG 16	TA 030 DCMT 11	TA 032 VCMT 16	TA 034 VBMT 16
						
TA 040 16'LİK IR-ER	TA 045 MTJNR 22	TA 050 SNMG 12	TA 046 KNUX 16 (SAĞ)	TA 048 KNUX 16 (SOL)		

BASKI KEPLERİ / Clamp

						
BK 018 CNMG 19	BK 020 D TİPİ	BK 021 CNMG 16	BK 022 MTJNR 16	BK 023 MTJNR 22	BK 024 D TİPİ (KÜÇÜK)	BK 026 MWLNR 08
						
BK 028 KNUX (SAĞ)	BK 030 KNUX (SOL)	BK 031 KNUX (SAĞ)	BK 032 KNUX (SOL)	BK 036 TPKN 16	BK 038 TPKN 22	